

Instructions for Use

RM2265

Rotary Microtome



**Instructions for Use**

Leica RM2265

V 1.8 RevC, English 07/2013

**Order No.** 14 0503 80101 RevC

Always keep this manual with the instrument.

Read carefully before working with the instrument.





## NOTE

---

The information, numerical data, notes and value judgments contained in this manual represent the current state of scientific knowledge and state-of-the-art technology as we understand it following thorough investigation in this field.

We are under no obligation to update the present manual periodically and on an ongoing basis according to the latest technical developments, nor to provide our customers with additional copies, updates etc. of this manual.

To the extent permitted in accordance with the national legal system as applicable in each individual case, we shall not be held liable for erroneous statements, drawings, technical illustrations etc. contained in this manual.

In particular, no liability whatsoever is accepted for any financial loss or consequential damage caused by or related to compliance with statements or other information in this manual.

Statements, drawings, illustrations and other information regarding the contents or technical details of the present Instructions for Use are not to be considered warranted characteristics of our products.

These are determined only by the contract provisions agreed between ourselves and our customers.

Leica reserves the right to change technical specifications as well as manufacturing processes without prior notice. Only in this way is it possible to continuously improve the technology and manufacturing techniques used in our products. This document is protected under copyright laws. All copyrights to this documentation are held by Leica Biosystems Nussloch GmbH.

Any reproduction of text and illustrations (or of any parts thereof) by means of print, photocopy, microfiche, web cam or other methods – including any electronic systems and media – requires express prior permission in writing by Leica Biosystems Nussloch GmbH.

For the instrument serial number and year of manufacture, please refer to the identification label attached to the instrument.

© Leica Biosystems Nussloch GmbH



Leica Biosystems Nussloch GmbH

Heidelberger Str. 17 - 19

D-69226 Nussloch

Germany

Phone: +49 6224 143-0

Fax: +49 6224 143-268

Internet: <http://www.LeicaBiosystems.com>

Assembly contracted to Leica Microsystems Ltd. Shanghai.

# Table of Contents

<b>1.</b>	<b>Important Information</b> .....	<b>4</b>
1.1	Symbols in the text and their meanings .....	4
1.2	Qualification of personnel.....	5
1.3	Intended use of instrument.....	5
1.4	Instrument type.....	5
<b>2.</b>	<b>Safety</b> .....	<b>6</b>
2.1	Safety notes .....	6
2.2	Warnings .....	6
2.3	Integrated safety devices .....	9
<b>3.</b>	<b>Instrument Components and Specifications</b> .....	<b>11</b>
3.1	Overview – instrument components .....	11
3.2	Instrument specifications .....	12
3.3	Technical data .....	13
<b>4.</b>	<b>Instrument Setup</b> .....	<b>15</b>
4.1	Installation site requirements .....	15
4.2	Standard delivery .....	15
4.3	Unpacking and installation .....	16
4.4	Assembling the hand wheel .....	18
4.5	Electrical connections.....	18
4.6	Switching on the instrument .....	21
<b>5.</b>	<b>Operation</b> .....	<b>22</b>
5.1	Controls and their functions .....	22
5.1.1	Instrument control panel.....	22
5.1.2	Control panel.....	23
5.1.3	Display and control elements.....	24
5.2	Inserting the knife holder.....	37
5.3	Inserting the standard clamp .....	38
5.4	Adjusting the clearance angle.....	39
5.5	Clamping the specimen.....	40
5.6	Clamping the knife/disposable blade.....	40
5.7	Trimming the specimen.....	42
5.7.1	Trimming in manual operation .....	42
5.7.2	Trimming in motorized operation.....	42
5.8	Sectioning.....	43
5.9	Changing the specimen or interrupting sectioning .....	43
<b>6.</b>	<b>Optional Accessories</b> .....	<b>44</b>
6.1	Assembly for specimen holder fixture .....	44
6.1.1	Rigid fixture for specimen clamps.....	44
6.1.2	Directional fixture for specimen clamps .....	44
6.1.3	Fine-directional fixture for specimen clamps.....	45

## Table of Contents

6.1.4	Quick clamping system .....	46
6.1.5	Super mega cassette clamp.....	47
6.2	Specimen clamps and inserts.....	48
6.2.1	Standard specimen clamp.....	48
6.2.2	Vee insert.....	49
6.2.3	Foil clamp type 1.....	50
6.2.4	Universal cassette clamp .....	51
6.2.5	Round specimen holder .....	52
6.2.6	Specimen holders .....	53
6.2.7	Specimen holder fixture.....	53
6.3	Knife holder base and knife holder .....	54
6.3.1	Knife holder base, without lateral displacement feature .....	54
6.3.2	Knife holder E/E-TC.....	55
6.3.3	Knife holder N/NZ.....	58
6.3.4	Knife holder GD.....	60
6.4	Blades/knives.....	61
6.4.1	Disposable blades.....	61
6.4.2	Knife.....	61
6.5	Section waste tray.....	63
6.6	Backlighting .....	63
6.7	Freezer pack.....	64
6.8	LN22.....	64
6.9	Universal microscope carrier .....	65
6.10	Magnifying lens .....	67
6.11	Cold-light source .....	68
6.12	Fiber-optic light guide.....	68
6.13	Ordering information.....	69
<b>7.</b>	<b>Troubleshooting .....</b>	<b>71</b>
7.1	Instrument malfunctions .....	71
7.1.1	Error codes.....	71
7.1.2	Instrument malfunctions, possible causes and remedies.....	71
7.2	Possible faults.....	73
<b>8.</b>	<b>Cleaning and Maintenance .....</b>	<b>76</b>
8.1	Cleaning the instrument.....	76
8.2	Maintenance.....	78
8.2.1	Changing fuses .....	78
8.2.2	Maintenance instructions.....	79
8.2.3	Lubricating the instrument.....	80
<b>9.</b>	<b>Warranty and Service .....</b>	<b>81</b>
<b>10.</b>	<b>Decontamination Certificate.....</b>	<b>82</b>

# 1. Important Information

## 1.1 Symbols in the text and their meanings



**Warnings** appear in a gray box and are marked by a warning triangle .



**Notes**, i.e. important user information appears in a gray box and is marked by an information symbol .

(5)

**Numbers in parentheses refer to item numbers in illustrations.**

**RUN/  
STOP**

**Function keys which must be pressed on the control panel are shown in the text in bold capital letters.**



Manufacturer



Date of Manufacture



This product fulfills the requirements of the Council's Directive 98/79/EC concerning in vitro diagnostics (IVD) medical devices.



In vitro diagnostics (IVD) medical device



Observe the Instructions for Use



Order No.



Serial number



Symbol for labeling electrical and electronic equipment in accordance with Section 7 of the German Electrical and Electronic Equipment Act (ElektroG). ElektroG is the law on the bringing into circulation, return and environmentally compatible disposal of electrical and electronic equipment.



The CSA test mark means that a product has been tested and fulfills the applicable safety and/or performance standards, including the relevant standards defined or administered by the American National Standards Institute (ANSI), Underwriters Laboratories (UL), the Canadian Standards Association (CSA), the National Sanitation Foundation International (NSF) and others.



Environmental protection symbol of the China RoHS directive. The number in the symbol indicates the "Environment-friendly Use Period" of the product. The symbol is used if a substance restricted in China is used in excess of the maximum permitted limit.

## 1.2 Qualification of personnel

- The Leica RM2265 may be operated by trained laboratory personnel only.
- All laboratory personnel designated to operate the Leica instrument must read these Instructions for Use carefully and must be familiar with all technical features of the instrument before attempting to operate it.

## 1.3 Intended use of instrument

The Leica RM2265 is a fully automatic, motorized rotary microtome with a separate control panel for creating thin sections of specimens of varying hardness for use in routine and research laboratories in the fields of biology, medicine and industry.

It is designed for cutting both soft paraffin and harder specimens, as long as they are suitable for being cut manually or automatically.

The Leica RM2265 is also suitable for IVD (in vitro diagnostics).

**Any other use of the instrument will be considered as improper use!**

## 1.4 Instrument type

All information provided in these Instructions for Use applies only to the instrument type indicated on the title page.

An identification label with the serial number is fastened to the left side of the instrument (this figure is only symbolic).

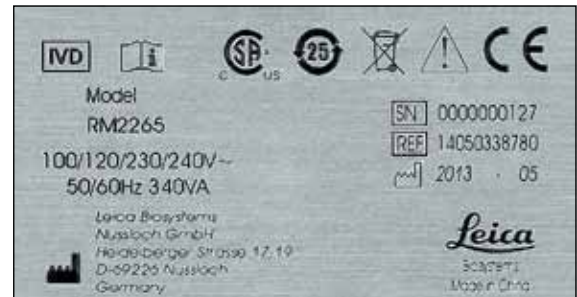

Fig. 1

## 2. Safety

---



**The safety and caution notes in this chapter must be observed at all times. Be sure to read these notes even if you are already familiar with the operation and use of other Leica products.**

### 2.1 Safety notes

These Instructions for Use include important information related to the operating safety and maintenance of the instrument.

The Instructions for Use are an important part of the product, and must be read carefully prior to startup and use and must always be kept near the instrument.



**These Instructions for Use must be appropriately supplemented as required by the existing regulations on accident prevention and environmental safety in the operator's country.**

This instrument has been built and tested in accordance with the safety regulations for electrical measuring, control, regulating and laboratory devices.

To maintain this condition and ensure safe operation, the user must observe all notes and warnings contained in these Instructions for Use.

For current information about applicable standards, please refer to the CE declaration of conformity on our Internet site:

**[www.LeicaBiosystems.com](http://www.LeicaBiosystems.com)**



**The protective devices located on the instrument and the accessories must not be removed or modified. Only service personnel qualified by Leica may repair the instrument and access the instrument's internal components.**

### 2.2 Warnings

The safety devices installed in this instrument by the manufacturer only constitute the basis for accident prevention. Operating the instrument safely is, above all, the responsibility of the owner, as well as the designated personnel who operate, service or clean the instrument.

To ensure trouble-free operation of the instrument, make sure to comply with the following instructions and warnings.



### Warnings – Safety notes on the instrument itself



- Safety notes on the instrument itself, which are marked with a warning triangle, indicate that the correct operating instructions (as defined in these Instructions for Use) must be followed when operating or replacing the item marked.
- Failure to adhere to these instructions may result in an accident, personal injury, damage to the instrument or accessory equipment.

### Warnings – Transport and installation



- Once unpacked, the instrument may be transported only in an upright position.
- Never lift the instrument by the handwheels or the cassette clamp. Always remove the section waste tray before transporting the instrument.
- Caution! The voltage selector has been preset at the factory.
- Before connecting the instrument to the line voltage, please check that this setting complies with the local power requirements of your laboratory.
- The mains cable inlet is closed with an adhesive tape that indicates the actual voltage setting of the instrument upon arrival. Severe damage can be caused to the instrument if the voltage selector is set to an incorrect voltage!
- When adjusting the voltage selector setting, the instrument must be disconnected from the mains.
- The instrument must be connected to mains only with one of the supplied power cords and only to grounded sockets. Do not interfere with the grounding function by using an extension cord without a ground wire.
- The instrument is ready for operation only if a dummy plug or foot switch (optional) is connected. If you hear a beeping sound (continuous) after switching on the instrument, check that the control panels are connected correctly.
- The instrument may not be operated in hazardous locations.
- Extreme temperature fluctuations between storage facility and setup site as well as high humidity may cause condensation to form. If this is the case, wait at least two hours before switching on the instrument. Failure to comply with this may cause damage to the instrument.
- Protective devices on both instrument and accessories must neither be removed nor modified.

### Personal safety precautions



- When working with microtomes, personal safety precautions must always be taken. It is mandatory to wear work safety shoes, safety gloves, a mask and safety goggles.

## 2. Safety

---

### Safety instructions – working with the instrument



- Take care when handling microtome knives and disposable blades. The cutting edge is extremely sharp and can cause serious injuries!
- Always remove the knife / blade before detaching the knife holder from the instrument. Always put the knives back into the knife case when not in use!
- Never place a knife anywhere with the cutting edge facing upwards and never try to catch a falling knife!
- Always clamp the specimen block BEFORE clamping the knife or blade.
- Lock the handwheel and cover the knife edge with the knife guard prior to any manipulation of knife or specimen clamp, prior to changing the specimen block and during all work breaks!
- ALWAYS turn the handwheel clockwise; otherwise, the brake will not work properly.
- Always take appropriate safety precautions when sectioning brittle specimens! Specimens may splinter!
- Ensure that liquids do not enter the interior of the instrument during work!
- Do not attempt to clamp, approach or orient the specimen during the retraction phase.
- If a block is oriented during retraction, the block will advance by the retraction value PLUS the selected section thickness before the next section. This may cause damage to both specimen and knife!
- The handle of the handwheel must always be centered while in motorized sectioning mode. Do not touch the handwheel while it is running – there is a danger of injury from the handwheel lock.
- Prior to sectioning, check that the specimen is securely clamped in the specimen clamp – failure to observe this poses the risk of damaging the specimen.

### Hazards – servicing and cleaning



- Only authorized and qualified service personnel may access the internal components of the instrument for service and repair!
- Before each cleaning, switch off the instrument, disconnect the power plug, remove the knife holder completely and clean it separately.
- Always remove the blade before detaching the knife holder from the instrument.
- Lock the handwheel before each cleaning!
- Do not use any solvents containing acetone or xylene for cleaning!
- Ensure that liquids do not enter the interior of the instrument during cleaning!
- Do not turn the instrument on before it is completely dry!
- When using detergents please comply with the safety precautions of the manufacturer.
- Turn the instrument off with the power switch and disconnect the power plug before replacing the fuses! Only use fuses of the same specification! For fuse specifications, refer to [Chapter 3.3 – "Technical Data"](#).

## 2.3 Integrated safety devices

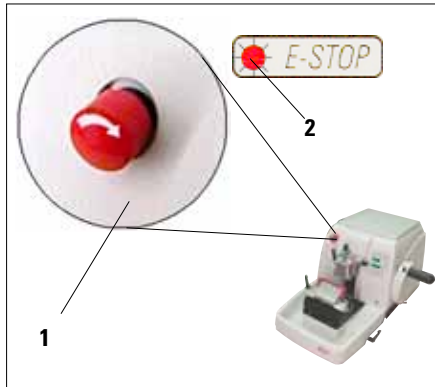

Fig. 2

### Emergency-stop function

The emergency-stop function is activated with the red **EMERGENCY STOP** switch (1) on the upper left of the front of the microtome. The sectioning motor stops immediately when the **EMERGENCY STOP** switch is pressed. The red LED in the **E-STOP** field (2) on the control panel of the instrument lights up, indicating that the emergency stop function has been activated.

To deactivate this function, turn the **EMERGENCY STOP** switch in the direction of the arrow.



Fig. 3

### Handwheel lock (manual operation only)

- To lock the handwheel, push the lever (5) outwards and continue to turn the handwheel slowly until it locks exactly in the 12 o'clock position. The LED (4) in the **LOCK** display lights up.



**Caution!**  
Never operate the lever (5) during motorized sectioning.

### Handwheel brake

Using the lever (3) on the right side of the microtome base plate, the handwheel can be braked in any position.

- To lock the handwheel, pull the lever forward forcefully.
- To unlock the handwheel brake, push the locking lever (3) back to its original position.



### Important!

The LED (4) in the **M-STOP** field indicates only that the instrument cannot be started. It does not provide any indication that the handwheel brake is active.

The lever (3) must be pulled completely forward with force so that the handwheel brake is applied. The handwheel is securely locked only when the lever (5) is in the 12 o'clock position.

## 2. Safety

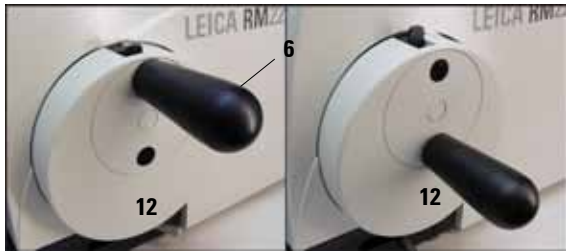

Fig. 4

### Centering the handle

For safety reasons, the handle of the handwheel must always be centered while in motorized sectioning mode.

- Activate the handwheel lock.
- To center the handwheel, lightly pull the handle (6) outwards and swivel it into the center of the handwheel (12) (Fig. 4).
- The handle will then lock automatically when released.

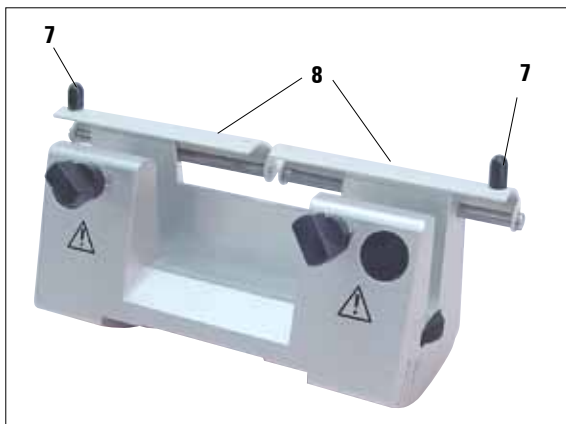

Fig. 5

### Knife guard on the knife holder

Each knife holder is equipped with a tightly mounted knife guard (8, 9). This makes it possible to cover completely the cutting edge in every knife or blade position.

### Knife holder N/NZ

The knife guard (8) of the knife holder N/NZ can be easily positioned via the two handles (7) (Fig. 5).

To cover the knife edge, push both cover strips of the knife guard to the center.

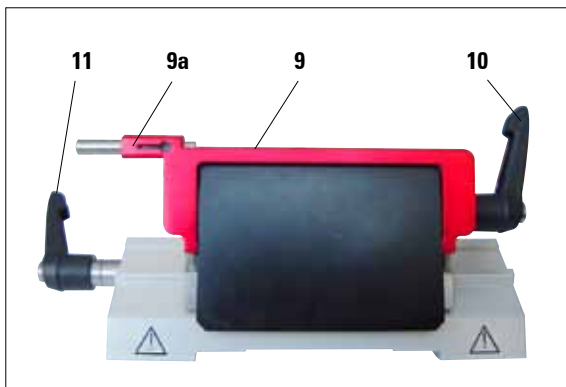

Fig. 6

### Knife holder E

The knife guard on knife holder E consists of a red foldaway handle with ejector (9a). To cover the cutting edge, fold the knife guard handle (9) upwards as illustrated in Fig. 6.



For the new knife holder E, the two clamping levers (10, 11) must always remain in the position shown. Clamping lever for the blade (10) at the right, clamping lever for the lateral displacement (11) at the left.

### 3. Instrument Components and Specifications

#### 3.1 Overview – instrument components

Leica RM2265



Fig. 7

### 3. Instrument components and specifications

---

#### Rear side of instrument



Fig. 8

#### 3.2 Instrument specifications

The Leica RM2265 is a motorized rotary microtome.

- The specimen feed system with zero-backlash and maintenance-free cross roller guides and the stepper motor operated coarse feed system are located in a dust-proof plastic housing.
- The instrument is equipped with a safety handwheel with a handle that can be centered, as well as a mechanical handwheel lock.
- All controls and LEDs are centralized in a separate control panel. All control elements are logically arranged in functional groups and easily identifiable.
- The specimen retraction can be turned off. In manual operation the retraction can be adjusted. In motorized operation the retraction value varies with the selected sectioning speed. An LED illuminates while the sample is in retraction.
- The electric coarse feed operates at two speeds. In the sectioning mode, the coarse feed buttons have a STEP function.
- Four motorized sectioning modes (**CONT**, **SINGLE**, **STEP** and **PROG**) are available as well as one manual sectioning mode, the rocking mode (**ROCK**). In rocking mode, it is enough to move the handwheel a short distance back and forth in order to create a section.

### 3.3 Technical Data

#### General

Approvals:	The instrument-specific marks are located on the rear panel of the instrument next to the nameplate.
Nominal supply voltages:	100 / 120 / 230 / 240 V AC $\pm 10\%$
Nominal frequency:	50/60 Hz
Maximum power consumption:	40 VA
Protection class <sup>①</sup> :	I
Power fuses:	2 x T 3.2 A UL listed
Pollution degree <sup>①</sup> :	2
Overvoltage category <sup>①</sup> :	II
Maximum heat emission:	340 J/s
Operating temperature range:	+10 °C to +35 °C
Temperature range during storage:	+5 °C to +55 °C
Relative humidity:	max. 80 % non-condensing
Storage humidity:	< 80 %

<sup>①</sup> according to IEC-1010, UL 3101, EN 61010

#### Dimensions and weight

##### Basic instrument

Width (including handwheel):	413 mm
Width (excluding handwheel):	300 mm
Depth (including waste tray):	563 mm
Height (total):	305 mm (with tray on the hood)
Working height (knife blade):	100 mm (measured from the base plate)
Working height (knife blade):	168 mm (measured from the table)
Weight (without accessories):	approx. 37 kg

##### Control panel

Width:	121 mm
Depth:	166 mm
Height:	50 mm
Height (in inclined position):	81 mm
Weight (net):	approx. 0.660 kg

### 3. Instrument components and specifications

---

#### Microtome

##### Sectioning thickness setting:

Section thickness setting range:	0.25 - 100 $\mu\text{m}$	
Setting values:	0.25 $\mu\text{m}$	
	0.50 - 5.0 $\mu\text{m}$	in 0.5 $\mu\text{m}$ increments
	5.0 - 20.0 $\mu\text{m}$	in 1.0 $\mu\text{m}$ increments
	20.0 - 60.0 $\mu\text{m}$	in 5.0 $\mu\text{m}$ increments
	60.0 - 100.0 $\mu\text{m}$	in 10.0 $\mu\text{m}$ increments

##### Trimming section thickness setting range: 1 - 600 $\mu\text{m}$

Setting values:	1.0 - 10.0 $\mu\text{m}$	in 1.0 $\mu\text{m}$ increments,
	10.0 - 20.0 $\mu\text{m}$	in 2.0 $\mu\text{m}$ increments,
	20.0 - 50.0 $\mu\text{m}$	in 5.0 $\mu\text{m}$ increments,
	50.0 - 100.0 $\mu\text{m}$	in 10.0 $\mu\text{m}$ increments,
	100.0 - 600.0 $\mu\text{m}$	in 50.0 $\mu\text{m}$ increments.

Specimen feed: 28 mm  $\pm$ 1 mm, feed motion via step motor

Vertical stroke: 70 mm

Maximum sectioning area w/o retraction: 65 mm without specimen orientation

Maximum sectioning area with retraction: 60 mm

##### Specimen retraction:

in manual sectioning mode: 5 - 100  $\mu\text{m}$  in 5  $\mu\text{m}$  increments; can be turned off

in motorized sectioning mode: Varies with the sectioning speed; can be turned off

Electric coarse feed: 300  $\mu\text{m}/\text{s}$  and 900  $\mu\text{m}/\text{s}$

Sectioning speed: 0.5 - 420 mm/s  $\pm$ 10 %

Return speed approx. 120 - 420 mm/s  $\pm$ 10 %

##### Repositioning of knife holder base

North-south: 24 mm

Maximum specimen size (L x H x W): 50 x 60 x 40 mm

##### Specimen orientation

Horizontal: 8°

Vertical: 8°



### 4.1 Installation site requirements

- Stable, vibration-free laboratory bench with horizontal, even stage plate; practically vibration-free floor.
- No other instruments nearby which might cause vibrations.
- Room temperature consistently between + 10 °C and + 35 °C.
- Obstruction-free access to the handwheel.



**Never operate the instrument in rooms with an explosion hazard.**

### 4.2 Standard delivery

The Leica RM2265 standard delivery includes:

1 Leica RM2265 basic instrument, without orientation .....	14 0503 38780
1 handwheel, complete .....	14 0502 37734
1 external control panel.....	14 0503 38781
1 section waste tray .....	14 0503 39060
1 dummy plug .....	14 0443 30420
1 set of power cables consisting of:	
1 power cable for Germany.....	14 0411 36958
1 power cable for USA/Canada/Japan .....	14 0411 36960
1 power cable for UK ST/BU F-5A.....	14 0411 36959
1 tool set - consisting of: .....	14 0502 37965
1 Allen key with handle, size 5.....	14 0194 04760
1 Allen key with handle, size 4.....	14 0194 04782
1 Allen key size 3.....	14 0222 04138
1 screwdriver 3x50, 186 long.....	14 0170 11568
1 bottle (50 ml) of oil for drives, type 405.....	14 0336 06086
2 micro-fuses 3.2 AT.....	14 9643 03201
1 "Leica" brush with magnet.....	14 0183 40426
1 dust protective cover.....	14 0212 30350
1 Instructions for Use for RM2265 (+ language CD).....	14 0503 80101



**The accessories are included at the top of the package (item 2 in Fig. 9). Check the delivery carefully against the packing list, delivery note and your order. Should you find any discrepancies, please contact your Leica sales office without delay.**

## 4. Instrument Setup

### 4.3 Unpacking and installation



When the instrument is delivered, check the tilt indicators on the packaging. If the arrowhead is blue, the shipment was transported laying flat, was tilted at too great an angle or fell over during transport. Note this on the shipping documents and check the shipment for possible damage.

Fig. 9

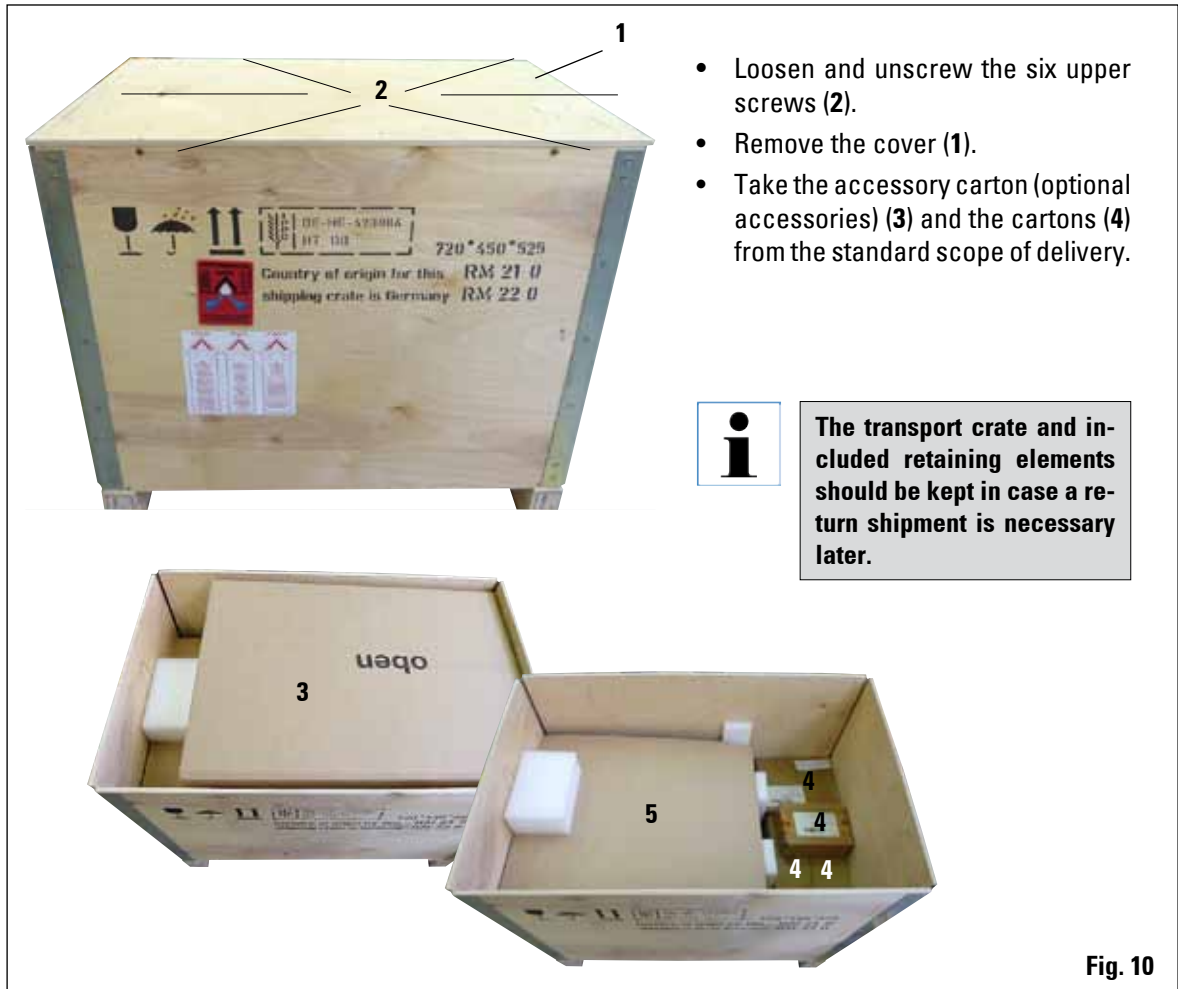
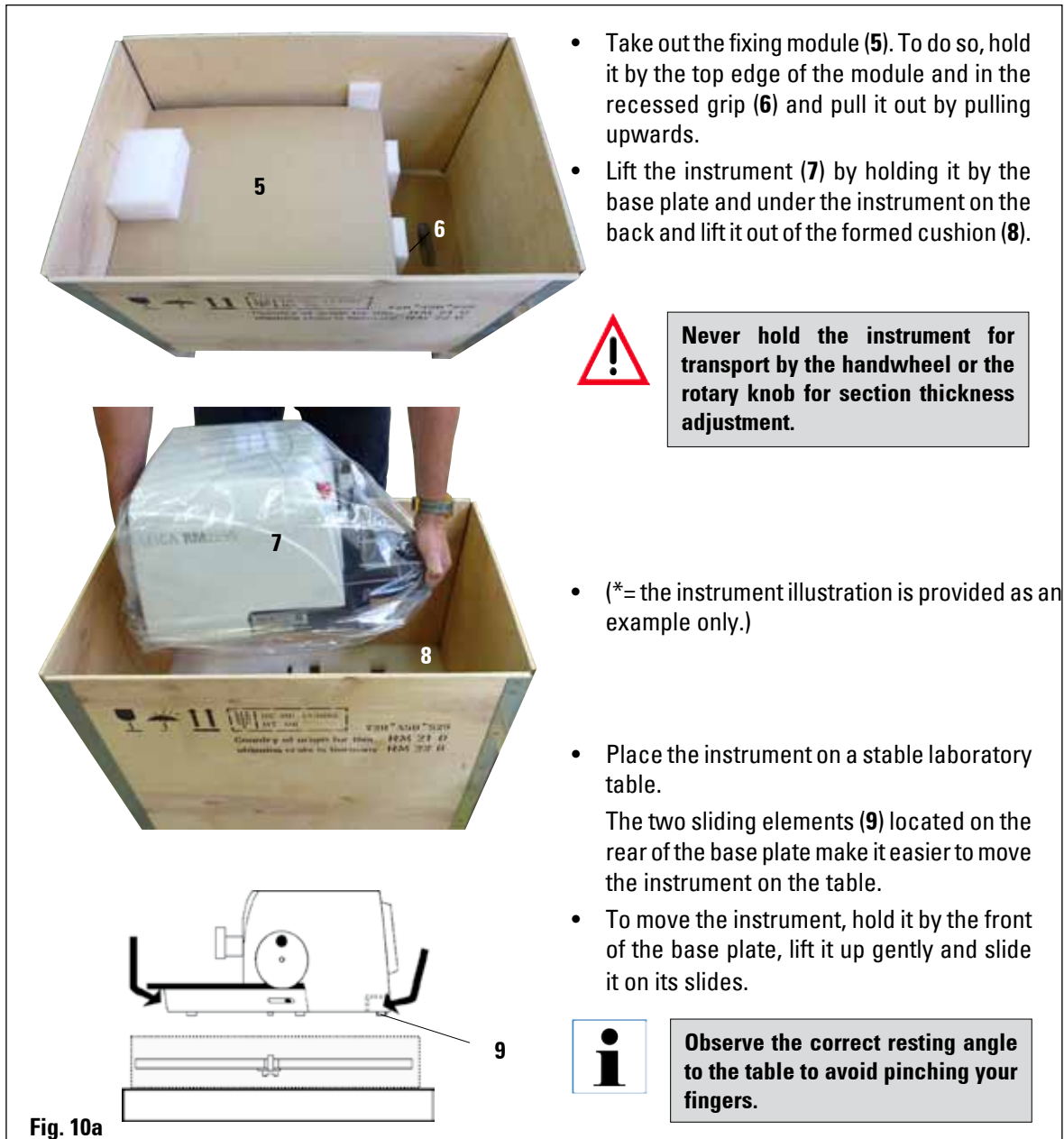



Fig. 10

### 4.3 Unpacking and installation (cont.)



- Take out the fixing module (5). To do so, hold it by the top edge of the module and in the recessed grip (6) and pull it out by pulling upwards.
- Lift the instrument (7) by holding it by the base plate and under the instrument on the back and lift it out of the formed cushion (8).



**Never hold the instrument for transport by the handwheel or the rotary knob for section thickness adjustment.**

- (\*= the instrument illustration is provided as an example only.)
- Place the instrument on a stable laboratory table.  
The two sliding elements (9) located on the rear of the base plate make it easier to move the instrument on the table.
- To move the instrument, hold it by the front of the base plate, lift it up gently and slide it on its slides.



**Observe the correct resting angle to the table to avoid pinching your fingers.**

**Fig. 10a**

## 4. Instrument Setup

### 4.4 Assembling the handwheel



The handwheel has to be assembled before attempting to use the instrument. The necessary parts and tools can be found in the toolkit.

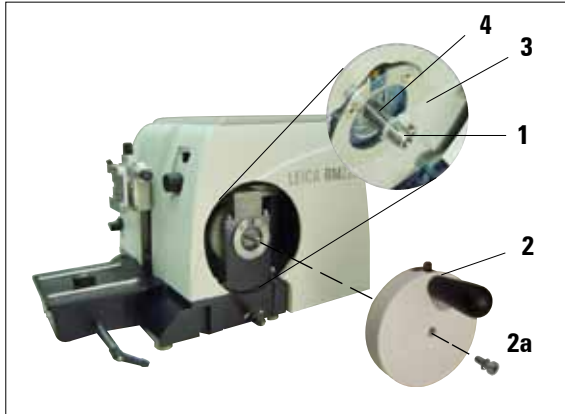

Fig. 11

The feather key (4) is loosely placed in the handwheel shaft (1) and fixed in place with a cable tie during transport.

- Remove the cable tie (3).  
Caution!  
Make sure not to lose the feather key!
- Place the handwheel (2) on the handwheel shaft (1) as shown.
- Tighten the screw (2a) located in the center hole of the handwheel with an Allen key size 4.
- Remove the cover foil from the self-adhesive cover disk and fix the cover disk on the handwheel.

### 4.5 Electrical connections



The instrument **MUST** be connected to a grounded power socket. Use only the power cable provided that matches the power supply (outlets) of the country of use. Do not use an extension cable without a ground wire!

#### Checking the voltage

The Leica RM2265 can be connected to various electrical power grids (depending on voltage and frequency) and, for this reason, is always delivered with a set of various power cables.

New instruments are factory-set to 230 volts. This is documented by a yellow label (**230 VOLT**) on the rear of the instrument, which covers the power switch and power socket.



**Before connecting the instrument to the power supply, be absolutely certain to check that the voltage selector is set to the voltage in use in your area!**  
**Severe damage can be caused to the instrument if the voltage selector is set to an incorrect voltage!**  
**Never change the setting of the voltage selector while the instrument is connected to the power supply.**

### Checking the voltage (continued)

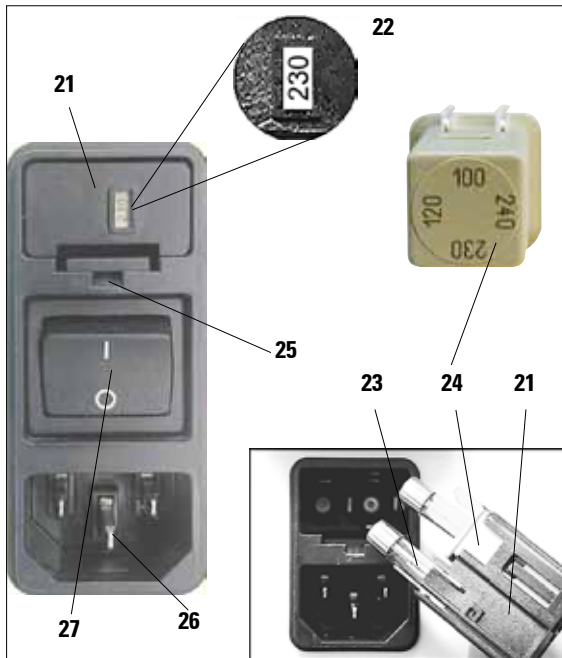

Fig. 12

The voltage selector is located above the main power switch, on the left-rear side of the instrument (Fig. 12). The voltage setting is displayed in the viewing window (22).

- Insert a small screwdriver into the cutout (25) and carefully pry out the insert.
- Remove the voltage selector housing (21) together with the fuses (23).

Remove the voltage selector block (24) (white) and insert it again such that the correct local voltage is displayed in the viewing window (22).

- Reinsert the voltage selector housing with the block and fuses and push it in until it engages (audible click).

### Connecting the power supply

- Before connecting the power cable, make sure that the power switch (27) on the rear of the instrument is switched to "0" = OFF.
- Various country-specific power cables are provided with the instrument. Make sure that the power cable used has the correct plug for the power socket.
- Insert the connector of the power cable into the connection socket (26) and plug the power plug into the power socket.



**Exposure to extreme temperature changes and high air humidity may cause condensation to form inside the instrument.**

**After transporting, wait at least 2 hours to allow the instrument to adopt the ambient temperature before turning it on!**

**Failure to comply with this may cause damage to the instrument.**

## 4. Instrument Setup

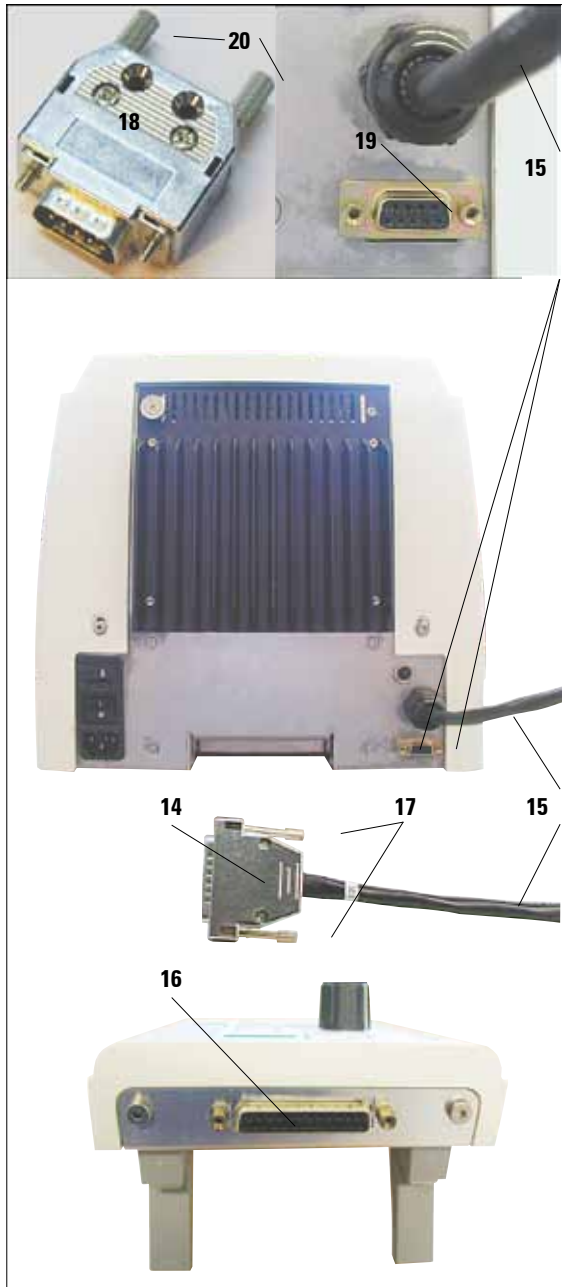

Fig. 13

### Connecting the dummy plug

- Insert the dummy plug provided (18) into the connecting jack (19) on the rear of the instrument and fasten it by tightening the screws (20).

### Connecting the foot switch (optional accessory)

- If a foot switch is to be used with the instrument, attach it in the same way as the dummy plug.



#### Caution!

If neither the dummy plug nor the foot switch is connected, the instrument is not ready for operation.

In this case, the E-STOP LED on the instrument is illuminated.



### Connecting the control panel

The connecting cable (15) of the control panel is fixed to the microtome. It may not be disconnected.

- Insert the plug (14) of the connecting cable (15) into the connecting jack (16) on the rear of the control panel.
- To fasten the plug, tighten the two screws (17).

## 4.6 Switching on the instrument



When turning the instrument on with the mains switch, do not press any of the buttons of the control panel or the foot switch (optional accessory)!

Turn the instrument on with the power switch at the rear.



This is followed by a beep.  
The instrument initializes.



The software version (shown here only as an example) is displayed in the 4-digit display. This display disappears after 2 seconds and "0000" is displayed.



After the microtome is switched on, the display fields and LEDs of all activated functions are lit up on the instrument's control panel and display field.

The three-digit LED display indicates the last value set for the section thickness or trimming thickness, depending on which setting was last activated. This is indicated simultaneously on the control panel and microtome.

The LED of the active mode (here the section thickness) is illuminated in green.

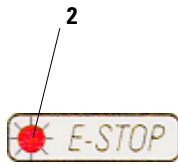

When the red LED in the **E-STOP** field (2) on the control panel of the instrument is illuminated, either

- the emergency-stop function has been activated (the EMERGENCY STOP button is pressed or the foot switch depressed).
- the dummy plug (or the optional foot switch) is not correctly connected to the jack, or not connected at all.



If the yellow LED in the **M-STOP** field (4) of the control panel is lit, the mechanical handwheel lock or the handwheel brake (Item 3 in Fig. 3) is activated.

The instrument cannot be used as long as the LED is lit.

## 5. Operation

### 5.1 Operating elements and their functions



The operating functions of the microtome are divided between a control panel and a display unit on the microtome.

A control panel on the instrument displays the current operating mode as well as various settings.

All operating functions are centrally located in the separate control panel. All keys and displays are logically arranged in functional groups and easily identifiable.

#### 5.1.1 Instrument control panel

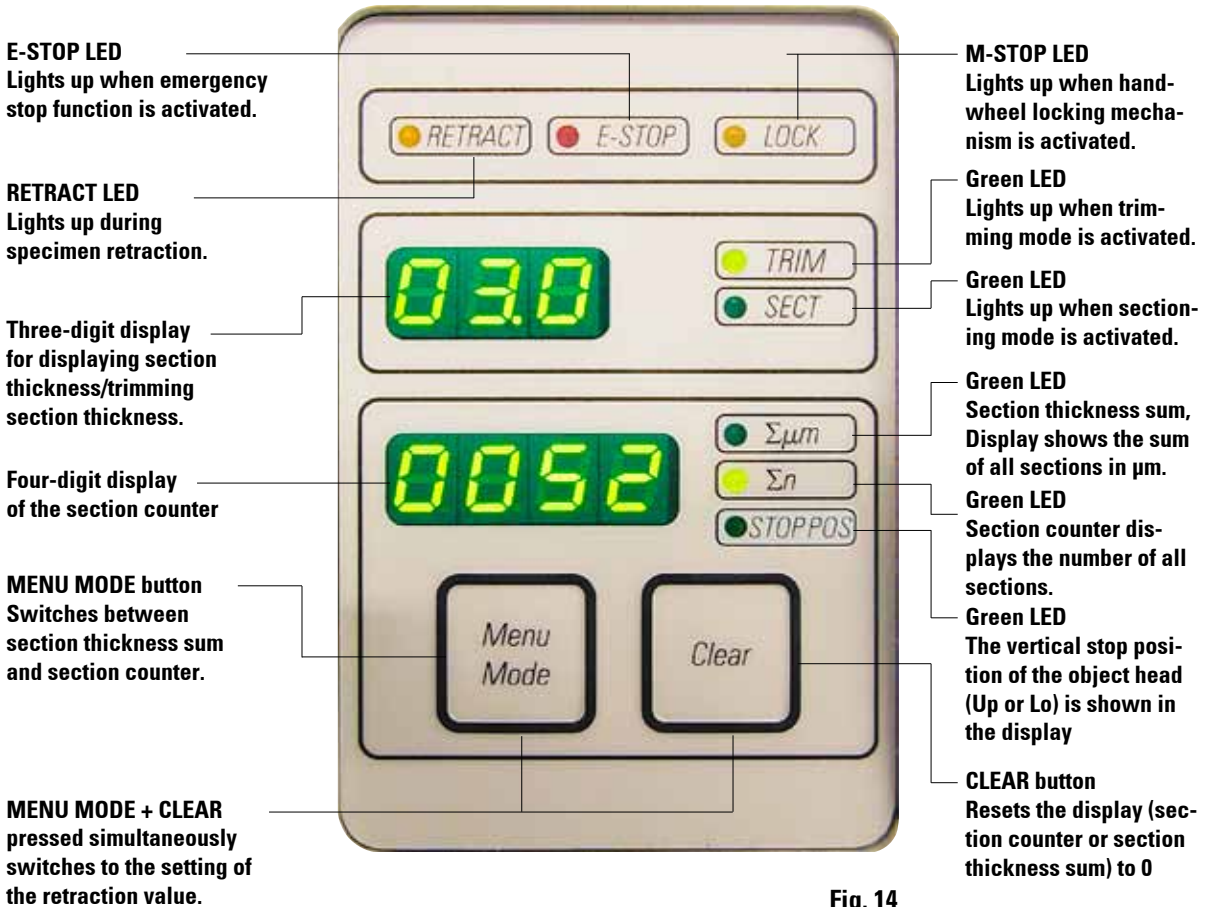

Fig. 14



## 5.1.2 Control panel

**Buttons**  
for setting the section thickness/  
trimming section thickness

**Rotary knob**  
For setting the sectioning speed

**Button**  
Set sectioning window

**Yellow LED** -  
Flashes during coarse feed backwards; lights up when rear end position is reached.

**Yellow LED** -  
Flashes during coarse feed forwards; lights up when front end position is reached.

**Coarse feed buttons**

**Trimming mode:**

<b>Backward fast coarse feed</b>	<b>Forward fast coarse feed</b>	<b>Forward slow coarse feed</b>	<b>Backward slow coarse feed</b>
----------------------------------	---------------------------------	---------------------------------	----------------------------------

**Sectioning mode:**

<b>Multiple step backward</b>	<b>Multiple step forwards</b>	<b>Single step forwards</b>	<b>Single step backward</b>
-------------------------------	-------------------------------	-----------------------------	-----------------------------



**Three-digit display**  
for section thickness/  
trimming section thickness.

**Green LED**  
Lights up when trimming mode is active.

**Green LED**  
Lights up when sectioning mode is activated

**CUT MODE button** -  
selection of operating mode

**Green LEDs**  
For displaying the active operating mode

**Green LED**  
Flashes until second sectioning window edge is set

**TRIM/SECT button**  
For switching between sectioning mode and trimming mode

**Yellow LED**  
Illuminated if the motor is switched on.

**Green LED**  
Illuminated if the motor is switched off or stops at the next stop position.

**Buttons**  
**RUN STOP** and **ENABLE**  
start and stop motorized sectioning.

Fig. 15

## 5. Operation

### 5.1.3 Display and control elements



Fig. 16

### Three-digit display

This display is located both on the instrument and on the control panel.

If the **SECT** LED is lit up, the display shows the section thickness setting in  $\mu\text{m}$ .

If the **TRIM** LED is lit up, the display shows the trimming section thickness setting in  $\mu\text{m}$ .

### Selecting the sectioning and trimming mode

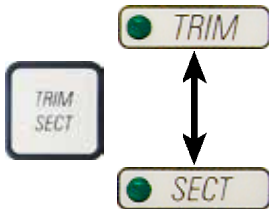

To switch between sectioning mode and trimming mode, press the **TRIM SECT** button. Whenever the button is pressed, the display toggles between **SECT** and **TRIM**.

In the **SECT** display, the sectioning thickness in the range from 0.25 to 100.0  $\mu\text{m}$  is shown, and in the **TRIM** display, the trimming section thickness between 1.0 and 600  $\mu\text{m}$  is displayed.

### Setting the section thickness/trimming section thickness



Adjust these settings using the  $\boxed{+}$  -  $\boxed{-}$  keys on the control panel.

Section thickness setting range: 0.25 - 100  $\mu\text{m}$

Setting values: 0.25  $\mu\text{m}$

from	0.5 $\mu\text{m}$ -	5.0 $\mu\text{m}$	in	0.5 $\mu\text{m}$ increments
from	5.0 $\mu\text{m}$ -	20.0 $\mu\text{m}$	in	1.0 $\mu\text{m}$ increments
from	20.0 $\mu\text{m}$ -	60.0 $\mu\text{m}$	in	5.0 $\mu\text{m}$ increments
from	60.0 $\mu\text{m}$ -	100.0 $\mu\text{m}$	in	10.0 $\mu\text{m}$ increments

Setting range for trimming section thickness: 1 - 600  $\mu\text{m}$

Setting values: from	1.0 $\mu\text{m}$ -	10.0 $\mu\text{m}$	in	1.0 $\mu\text{m}$ increments,
from	10.0 $\mu\text{m}$ -	20.0 $\mu\text{m}$	in	2.0 $\mu\text{m}$ increments,
from	20.0 $\mu\text{m}$ -	50.0 $\mu\text{m}$	in	5.0 $\mu\text{m}$ increments,
from	50.0 $\mu\text{m}$ -	100.0 $\mu\text{m}$	in	10.0 $\mu\text{m}$ increments,
from	100.0 $\mu\text{m}$ -	600.0 $\mu\text{m}$	in	50.0 $\mu\text{m}$ increments,

### Coarse feed functions



The electric coarse feed at two speeds is used for a rapid movement of the specimen towards and away from the knife. With the double-arrow buttons, the coarse feed operates at 900  $\mu\text{m/s}$ ; with buttons with one arrow, it is 300  $\mu\text{m/s}$ . In sectioning mode, the coarse drive can be used in (**STEP** mode) or with continuous feed. The instrument is delivered with continuous feed (standard configuration).

## Sectioning mode

### Button functions in STEP mode



Multiple step backward



Single step backward



Multiple step forward





Single step forward



In sectioning mode the user can select between **STEP function (step-by-step specimen feed)** and **continuous specimen feed**.

When continuous feed is selected, the coarse feed buttons have the same functions as in trimming mode. The **STEP** function is useful for careful step-by-step approximation of the specimen towards the blade.

How to activate the **STEP** function:

- Switch the instrument on while holding the  button on the control panel. (Likewise, to deactivate switch the instrument on while pressing the  button.) While the instrument is initializing, hold the  button until the software version number is no longer displayed (ensure that version number 2.1 was displayed).



This feature is only available in sectioning mode in version 2.1 or higher. For software versions older than 2.1, contact Leica Technical Service.

- Press **TRIM/SECT**  button and select sectioning mode (LED **SECT** lit).
- When pressing the button (with an arrow) for slow-speed coarse feed, a defined, incremental feed takes place (**STEP**) at the value indicated on the display in the respective direction (simple step).
- By short activation of a double-arrow coarse feed button, a single step is also effected in the appropriate direction.
- Longer activation of the double-arrow coarse feed button effects a repeated feed motion for as long as the button is pressed.

## Trimming mode



In the trimming mode, the coarse feed buttons operate a continuous movement as long as the button is held down. The double-arrow button for rapid coarse feed backward movements has a lock-in function.



### Backwards coarse feed



Forward coarse feed



Do not put your fingers between the specimen clamp and microtome to prevent pinching them.

- To start the rapid backwards movement (away from the blade), press the  key. After the  button is pressed, the specimen head is moved to the rear end position.
- To stop the movement, press any of the four coarse feed buttons.
- The yellow LED (40) in the button flashes while the specimen head is in motion, and remains lit continuously when the rear end position is reached.

## 5. Operation

- Press the  button to start the slow backwards movement. The travel continues as long as the button is held depressed.
- Press the appropriate button to start a rapid or slow forward movement. The travel continues as long as the button is held depressed.
- During the forwards movement, the yellow LED (**41**) in the button flashes. When the front end position is reached, an acoustic signal is heard and the LED stops flashing and remains lit.

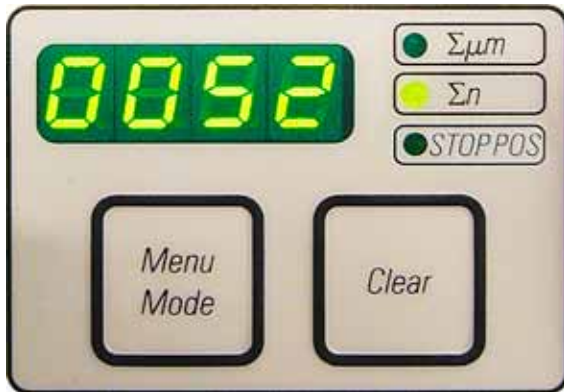

### Four-digit display on the instrument

The four-digit display is adjustable.

When the  $\Sigma \mu\text{m}$  LED is lit, the display shows the sum of the section thicknesses in  $\mu\text{m}$  for all sections completed since the instrument was switched on. (Section thickness sum)

When the  $\Sigma n$  LED is lit, the display shows the number of all previously completed sections.

Fig. 17



- To change the display mode, push **MENU MODE** until the LED of the desired mode is illuminated.
- Press **CLEAR** to reset section thickness sum or section number.
- This will only reset the currently displayed value.





**Caution! When the instrument is switched off using the main power switch, the values (section thickness sum and section number) are erased from memory.**

### Setting the vertical stop position



So that the instrument can work together optimally with the Leica LN22 nitrogen freezing device, the lower return point of the object head can be set as an additional stopping position.

- Push the **MENU MODE** button until the **STOP POS** LED is illuminated. The set stop position of the object head is indicated in the display. The default setting is the upper position (**UP**).
- Using the  and  buttons on the control panel, you can switch between the upper and lower (**UP, LO**) stop positions.

### Specimen retraction

To prevent damage to the blade and specimen, the specimen is moved away from the blade during the return motion to the upper home position.

In motorized sectioning mode, the retraction depends on the setting of the sectioning speed.

In manual mode, the retraction value can be selected in 5  $\mu\text{m}$  increments between 5 and 100  $\mu\text{m}$ . Specimen retraction is set to 10  $\mu\text{m}$  at the factory.

The specimen retraction can also be deactivated for the manual and motorized operation if required.

The selected setting is maintained when the instrument is turned off.

### Configuring the retraction settings





- To call up the retraction settings, press the **MENU MODE** and **CLEAR** buttons simultaneously.



- The current set value is displayed as a **three-digit number** in the four-digit display (e.g. "025" = 25  $\mu\text{m}$ ).



- Select the desired retraction value.  
The retraction value can be adjusted in increments of 5  $\mu\text{m}$  to a maximum of 100  $\mu\text{m}$  using the  -  buttons on the control panel.



- To exit the retraction settings, press **MENU MODE**.  
A retraction movement takes place by the newly selected value after each section.



- While the specimen is in retraction, the yellow LED on the **RETRACT** display (4) lights up.

## 5. Operation

---

### Switching off the specimen retraction



- To call up the retraction settings, press **MENU MODE** and **CLEAR** simultaneously.



- To switch off retraction, press the  button on the control panel until the display indicates "OFF".



- To exit the retraction settings, press **MENU MODE**.  
When retraction is switched off, the specimen is not retracted.



4



The yellow LED (4) of the **RETRACT** indicator does not light up.

### Setting the sectioning speed



- The sectioning speed can be set continuously (in the range of 0 - 420 mm/s) using the rotary knob.

The speed selector has a scale graduation from 1 to 10. The graduation is provided for reference purposes and does not indicate a particular speed.



**The set sectioning speed is only active within the boundaries of the sectioning area. A higher speed is used outside the sectioning area.**

### Sectioning window setting

The sectioning window function allows to optimally adapt the size of the sectioning area to the actual size of the specimen.

The selected sectioning window setting is maintained when the instrument is turned off.



- Turn the handwheel to position the lower edge of the sample approximately 3 mm above the cutting edge.
- Press the "**SET SECTIONING WINDOW**" button. This defines the first window border.
- The green LED (43) in the button flashes after the first window border is defined.
- Pass the specimen through to the upper border of the cutting edge and press the "**SET SECTIONING WINDOW**" button again.
- After the second window border is defined, the green LED in the button goes out. This indicates that both values were accepted.



**To set a sectioning window, you must always enter a pair of values. The sequence of entry (upper or lower) is optional.**

### Canceling a defined sectioning window



- To cancel a defined sectioning window before the start, press the "**SET SECTIONING WINDOW**" button once. This sets the sectioning area to the maximum size (corresponding to the entire sectioning area).

## 5. Operation



Fig. 18

### Sectioning modes

The microtome can be used both in manual and motorized operation.

You can choose between five settings:

**ROCK** in manual mode as well as **CONT**, **SINGLE**, **STEP** and **PROG** in motorized mode.



For safety reasons, when the instrument is first switched on, none of the operating modes is active.

### Mode selection

- For selecting the mode, press the **CUT MODE** button on the control panel until the green LED of the desired operating mode is displayed.

### Manual sectioning mode



- Select **ROCK** operating mode.
- Turn the handwheel a short distance forwards and backwards for sectioning (rocking mode).

Each change in the sense of rotation will be electronically detected and automatically converted into an advance or retraction movement of the specimen.



In the manual sectioning mode, it is possible to use either the conventional method of completing a full handwheel rotation or to work in the rocking mode ("Rock").

### Start and stop motorized sectioning



- To start motorized sectioning, press the **RUN/STOP** and **ENABLE** buttons simultaneously after selecting the desired operating mode.
- While the cutting motor is running, the yellow LED in the **RUN/STOP** key lights up.
- To stop motorized sectioning, press **RUN/STOP** or **ENABLE**.



If both the green and the yellow LEDs in the **RUN/STOP** button are lit up, the cutting motor is still running; however it will stop in the next programmed end position of the vertical stroke.



## Motorized sectioning

In motorized operation, you can choose between four operating modes:

- CONT** = continuous stroke
- SINGLE** = single stroke
- STEP** = step stroke
- PROG** = program mode



### CONT (continuous stroke) operating mode

- Select **CONT** operating mode.

After beginning the sectioning process, sectioning continues until the process is stopped by pressing **RUN/STOP** or **ENABLE**.

The specimen then stops in the next programmed end position of the vertical stroke, depending on which stop position is active.



### SINGLE (single stroke) operating mode

- Select **SINGLE** operating mode.

After starting sectioning, a single sectioning stroke is completed.

The specimen then stops automatically in the programmed end position of the vertical stroke.



**In motorized sectioning mode, the sectioning process can be started and stopped with the foot switch (optional accessory) instead of the **RUN/STOP** and **ENABLE** buttons. For additional information, refer to [Chapter 5, Operation, "Foot switch"](#).**



### STEP (step stroke) operating mode

- Select **STEP** (step stroke) operating mode.

After starting the sectioning process, the specimen is moved as long as the keys are held depressed (or as long as the foot pedal is pressed).

If the buttons or the foot switch are released, the specimen stops automatically.



## 5. Operation

---

### PROG – program mode



The RM2265 allows you to define a program for each mode (trimming, sectioning).

For both programs, the number of sections can be preset from 1 to 100. The cutting drive performs exactly as in **CONT** operating mode.

- Using the **CUT MODE** button, select the **PROG** operating mode. In the four-digit display on the instrument, the section program mode is indicated by a "P" followed by the number of preset sections, while the LEDs for the section counter, section thickness sum and stop position go out.

### Entering a program



- Use **TRIM/SECT** to select the desired mode.
- You can enter the desired programmed section number using the - buttons on the control panel. Pressing the button increases the section number by 1, and pressing the button decreases the section number by 1. The number appears immediately in the four-digit display of the instrument.

The maximum section number which can be programmed is 100.

### Executing a program

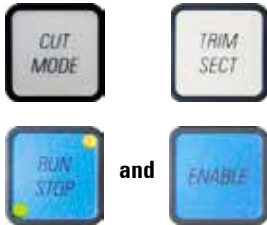

- Select the program mode using **CUT MODE** and select the cutting mode (trimming, sectioning) using **TRIM/SECT**. The number of sections for the program is shown in the display.
- To start the program, push **RUN/STOP** and **ENABLE** simultaneously.

If you interrupt a section program without first exiting PROG operating mode, the program is continued at the position at which it was stopped.

If you stop the section program prematurely and exit PROG sectioning mode (e.g. to change the section thickness), the current reading of the program counter is lost.

## Indication of remaining horizontal feed

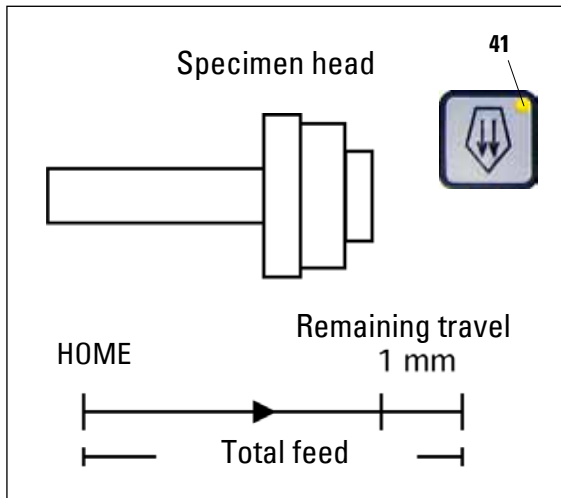

Fig. 19

The visible and audible remaining feed indication feature informs the user during trimming and sectioning when a remaining feed of approximately 1 mm is available before the front limit is reached.

The yellow LED (41) in the **COARSE FEED** button lights up from the beginning of the remaining feed. In addition, an acoustic signal is heard for approx. 2 seconds.

The sectioning process is interrupted and the object head stops in the upper end position.

From this point on, a remaining feed of approx. 1 mm is available.

In the remaining feed area, no more object feeding to the knife is possible using the coarse feed buttons.



and



- Restart motorized sectioning.

The yellow LED (41) in the **COARSE FEED** button lights up.

- When the front end position is reached, the sectioning process stops automatically.

- Upon restart, no more feed motion takes place.



or



- You can continue to work on the specimen by pressing the corresponding coarse feed button in the rear end position (**HOME**) and continuing with sectioning.



**To do so, you must press TRIM/SECT to switch to trimming mode, as otherwise, you cannot use the coarse feed.**

**If the specimen head is already in the remaining feed range when the instrument is switched on, an additional acoustic signal is heard after the software version is displayed.**

- You can continue to work on the specimen by moving it back a short distance using the coarse feed buttons (set trimming mode!).
- The **STEP** function is disabled in the remaining feed range.

## 5. Operation

### Foot switch (optional accessory)

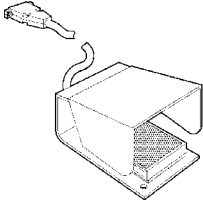

The foot switch can be used to control the motorized sectioning process. It also has a function that is similar to the emergency stop function.



#### Caution!

**In addition to the foot switch, all control panel functions and all buttons on the instrument continue to be active.**

- Using the **CUT MODE** button, select the desired operating mode, **CONT**, **SINGLE** or **STEP**, on the control panel (Fig. 18).



#### **CONT (continuous stroke) operating mode**

- Press the foot switch once briefly to start motorized sectioning.



**If the foot switch remains pressed for longer than half a second, the specimen stops in the next upper end position.**

- Press the foot switch again to stop it.  
The specimen then stops in the next programmed end position of the vertical stroke, depending on which stop position is active.



#### **SINGLE (single stroke) operating mode**

- Press the foot switch once briefly to start motorized sectioning. After each section, the specimen stops automatically in the end position, depending on which stop position is active (up or lo).



#### **STEP (step stroke) operating mode**

- Press down the foot switch once to start the sectioning process. The specimen is now moved for as long as the foot switch is depressed.
- If the foot switch is released, the specimen remains stationary in the position that it has reached.

#### **How to activate the emergency stop function**

- Press the foot switch strongly to activate the emergency stop function. Sectioning stops immediately.  
The red LED in the **E-STOP** field on the instrument (Fig. 14) is lit up as long as the foot switch remains depressed.
- To continue, restart the sectioning process using the foot switch. The operating mode remains unchanged.

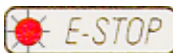

## Directional specimen holder fixture



In the quick clamping device of the directional specimen holder fixture, all specimen clamps available as optional accessories can be used (implemented).

The specimen orientation allows for simple position correction of the specimen surface when the specimen is clamped into place.

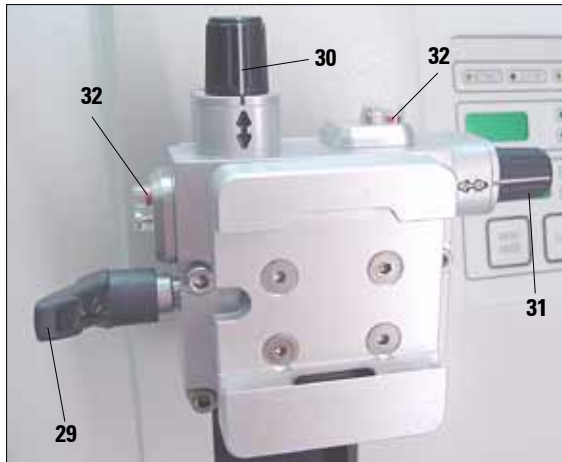

Fig. 20

### Display of the zero position

For better display of the zero position, the orientation has two red indicators (32).

When both indicators are visible and both setscrews (30, 31) are in zero position at the same time (click stop, white marking on "↕"), the specimen is in zero position.



When the large standard specimen clamp (50 x 55 mm) is used, the specimen orientation of 8° in north-south direction is no longer possible. The usable angle is only about 4° in this case.

The directional specimen holder fixture may be exchanged for a non-directional fixture (optional accessory).

### Orienting the specimen



**Specimen blocks must NOT be oriented during the retraction phase!**  
If a block is oriented during retraction, the block will advance by the retraction value PLUS the selected section thickness before the next section.  
This may cause damage to both specimen and knife!

- Raise the specimen head to the upper end position and activate the handwheel lock.
- To release the clamp, turn the eccentric lever (29) forwards.
- Turn setscrew (30) to orient the specimen in north-south direction. Turn setscrew (31) to orient the specimen in east-west direction.  
Each complete turn of the screw inclines the specimen by 2°. A total of 4 complete turns = 8° are possible in every direction. The accuracy is approximately ±0.5°.  
For ease of estimation, there is a white mark on the handle and a click stop that is noticeable during turning.
- To lock the current orientation, turn the eccentric lever (29) backwards.

## 5. Operation



Fig. 21

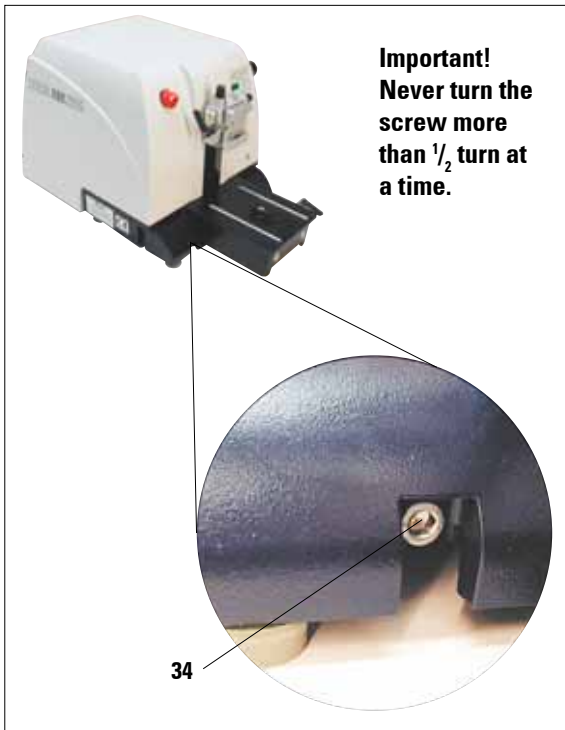

Fig. 22

### Fine adjustment of the force balance

If another accessory of a different weight is mounted on the specimen head (**33**), you must check whether it is necessary to readjust the force balance.

Checking the correct setting:

- Attach the new accessory and clamp the specimen.
- Set the specimen head to half the height of the vertical travel range by turning the handwheel (Fig. 21).

If the specimen head remains in this exact position, the setting is correct.

If the specimen head moves, i.e. it is raised or lowered, fine adjustment is necessary.



**Failure to adjust the force balance may result in injury while working.**

The force balance is adjusted using the screw (**34**), which can be accessed by removing the section waste tray on the bottom of the base plate of the microtome. Use the Allen key provided, No. 5 (with handle) for the adjustment.

- If the specimen head moves **downwards**, turn the screw approx.  $\frac{1}{2}$  turn **clockwise**.
- If the specimen head moves **upwards**, turn the screw (**34**) approx.  $\frac{1}{2}$  turn **counterclockwise**.
- Continue this procedure until the specimen head no longer moves once released.

### 5.2 Inserting the knife holder

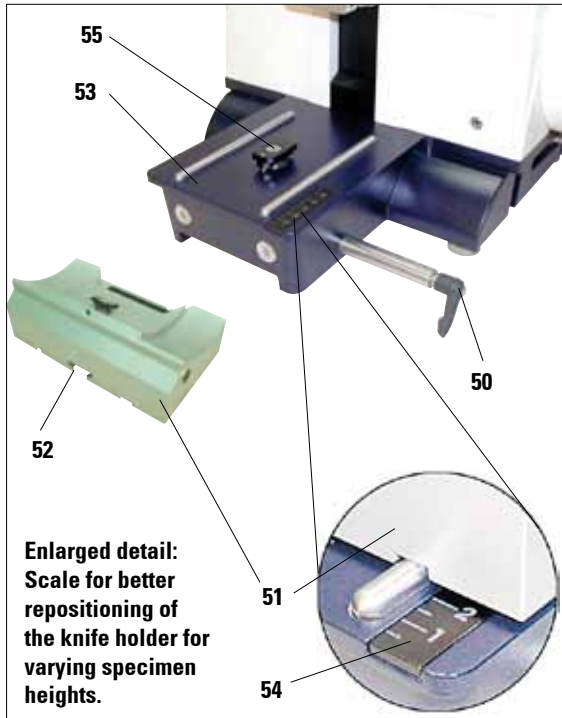

Fig. 23

### Setting up the knife holder base

- Release the clamping lever (50) by rotating it counterclockwise.
- Insert the knife holder base (51) using the notch (52) on the bottom into the T-piece (55) of the microtome base plate (53).
- To secure the knife holder base, turn the clamping lever (50) clockwise.

The knife holder base (51) can be moved back and forth on the microtome base plate. This allows bringing the knife holder to optimal sectioning position in relation to the specimen.

There is a scale (54) on the right side of the microtome base plate. This enables faster and better positioning of the knife holder at the specimen if various combinations of standard specimens and specimen holders are used. The rear edge of the knife holder base (51) functions as the scale reference.

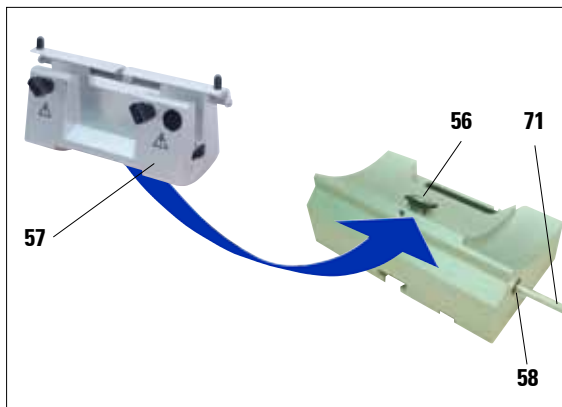

Fig. 24

### Inserting the knife holder

- Undo the screw (58) with an Allen key, size 4 (included in the delivery).
- Place the knife holder (57) with the underside groove onto the T-piece (56) of the knife holder base (51).
- To clamp, retighten the screw (58).

## 5. Operation

### 5.3 Inserting the standard clamp

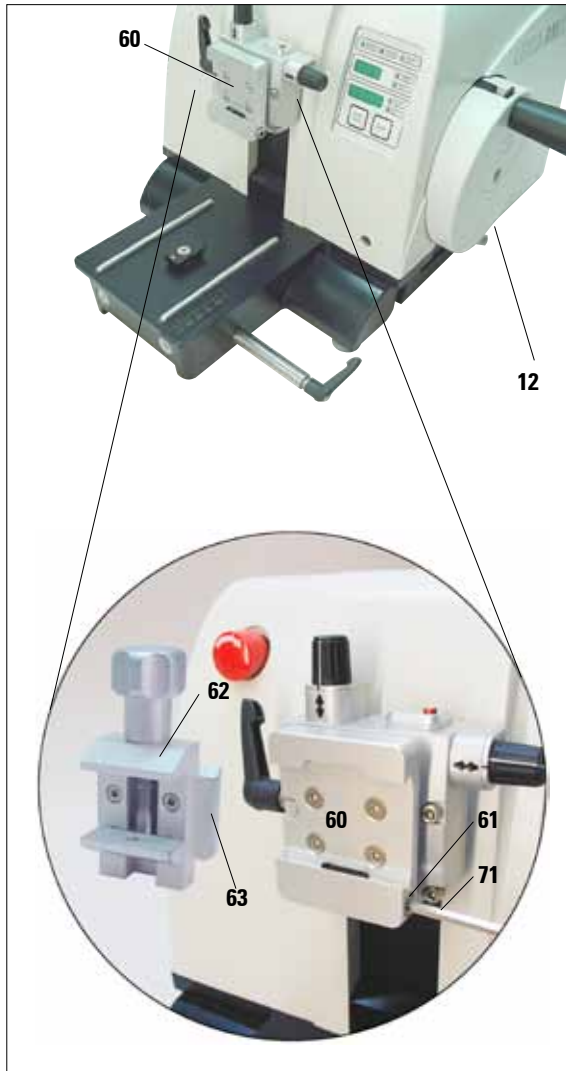

Fig. 25

There are two versions of the specimen holder fixture, one with and one without specimen orientation, which are interchangeable.

The specimen orientation allows for simple position correction of the specimen surface when the specimen is clamped into place.

You can use the specimen holder fixture (60) to hold all available accessory specimen clamps (for additional information, refer to [Chapter 6 "Optional Accessories"](#)).

To do so, proceed as follows:

- Move the specimen holder fixture (60) to the upper end position by turning the handwheel (12) and engage the handwheel lock.
- To release the clamping system, turn the screw (61) counterclockwise using an Allen key size 4 (71).
- Push the guide (63) of the standard clamp (62) from the left into the specimen holder fixture (60) as far as it will go.
- To clamp the specimen clamp, tighten the screw (61) in a clockwise direction using an Allen key size 4 (71).



### 5.4 Adjusting the clearance angle

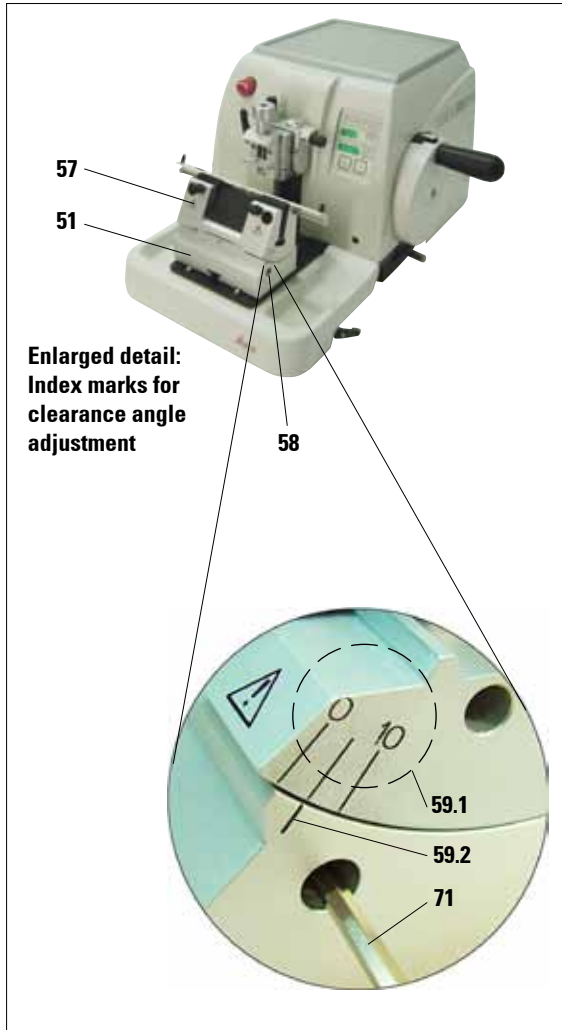

Fig. 26

- The index marks ( $0^\circ$ ,  $5^\circ$  and  $10^\circ$ ) for adjustment of the clearance angle (**59.1**) are located on the right side of the knife holder (**57**).
  - There is also an index mark (**59.2**) on the right side of the knife holder base (**51**) which serves as a reference point when adjusting the clearance angle.
  - Loosen the screw (**58**) using an Allen key No. 4 (**71**) until the knife holder (**57**) can be moved.
  - Move the knife holder until the index mark of the desired clearance angle coincides with the reference line on the knife holder base.
- Example:  
The enlarged detail illustration shows a clearance angle setting of  $5^\circ$ .



The recommended clearance angle setting for knife holder E is approx.  $5^\circ$ .

- Hold down the knife holder in this position and retighten the screw (**58**) for clamping.

## 5. Operation

### 5.5 Clamping the specimen



Always clamp the specimen block **BEFORE** clamping the knife or the blade. Lock the handwheel and cover the knife edge with the knife guard prior to any manipulation of knife or specimen, prior to changing the specimen block and during all work breaks!

- Rotate the handwheel until the specimen clamp is in the uppermost position.
- Activate the handwheel lock by allowing the handwheel handle to lock in place and then activate the brake.
- Insert a specimen into the specimen clamp.



A detailed description for inserting the specimen into various specimen clamps and specimen holders is provided in [Chapter 6 "Optional Accessories"](#).

### 5.6 Clamping the knife / disposable blade



Take care when handling microtome knives and disposable blades. The cutting edge is extremely sharp and can cause serious injuries!

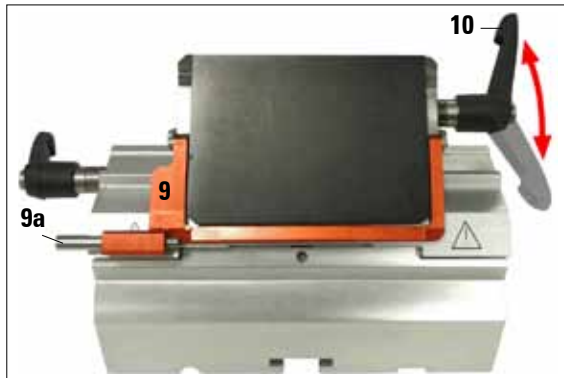

Fig. 27

- Fold knife guard (9) downward.
- To insert the blade, flip the right clamping lever (10) forward and down.

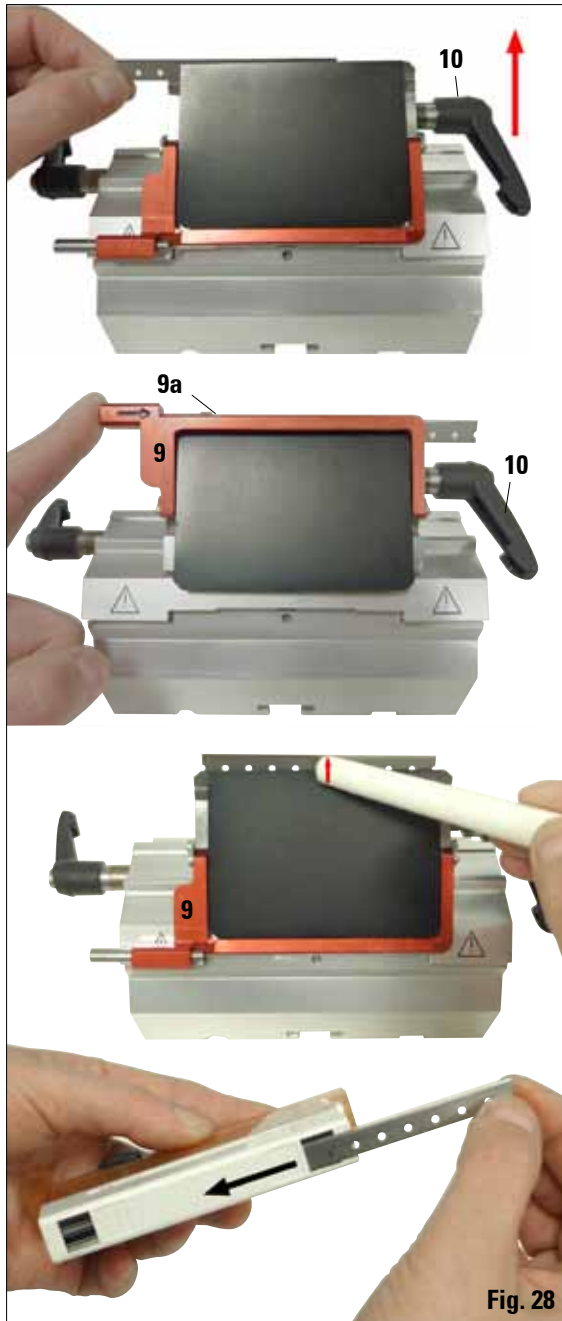

Fig. 28

- Carefully push in the blade from above or from the side. Make sure that the blade is clamped in the center and, most importantly, parallel to the upper edge of the pressure plate.
  - To clamp the blade, rotate clamping lever (10) clockwise back upwards.
  - To remove the blade, fold the clamping lever (10) downwards counterclockwise.
- The ejector (9a) ensures safe blade changing.



**Use the blade ejector to eject the blade!**

- Another option for removing the blade is to use the brush with magnet. To do so, fold the clamping lever (10) downwards counterclockwise. Likewise, fold the knife guard (9) downward. Guide the brush with magnet to the blade and lift it upwards and out.

Once the blade has been removed from the blade holder, it is disposed of into the dispenser container (underside, see image).

## 5. Operation

### 5.7 Trimming the specimen

#### 5.7.1 Trimming in manual operation



- Use the **TRIM/SECT** key to select the trim mode.
- Set the desired trim section thickness.
- Deactivate the handwheel lock and release the brake.
- In **TRIM** mode, use the coarse feed buttons to move the specimen against the knife/blade.
- Trim the specimen by turning the handwheel  
or
- Using the **CUT MODE** key, select the **ROCK** operating mode and cut the specimen with forward and backward motions of the handwheel.
- Terminate trimming when the desired sectioning surface and depth have been reached.



**During fast manual trimming, do not put your fingers between the specimen and knife. The handwheel continues turning after it is released and can cause injuries.**

#### 5.7.2 Trimming in motorized operation

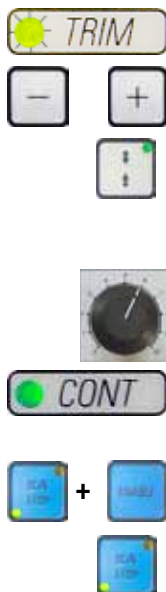

**The handle of the handwheel must always be centered while in motorized sectioning mode.**

- Use the **TRIM/SECT** key to select the trim mode.
- Set the desired trim section thickness.
- If necessary, set the sectioning window.



**Always set the sectioning speed according to the hardness of the specimen! For hard specimens, always select a slow speed.**

- Using the rotary knob, set the appropriate sectioning speed.
- Using the **CUT MODE** button, select the **CONT** operating mode (continuous stroke).
- Deactivate the handwheel lock and release the brake.
- Start motorized sectioning and trim the sample.
- Terminate trimming when the desired sectioning surface and depth have been reached.

## 5.8 Sectioning



Always use a different area of the cutting edge for trimming and sectioning. To do so, laterally displace the blade or knife in the knife holder.

When using the knife holder E with lateral displacement, it is sufficient to move the knife holder sideways.



- Center the handle of the handwheel.
- Use the **TRIM/SECT** key to select the sectioning mode.
- Adjust the appropriate sectioning thickness or verify the selected value.
- Depending on the operation planned, use the **CUT MODE** key to select one of the motorized sectioning modes, **CONT**, **SINGLE** or **STEP**.



Always turn the handwheel evenly in clockwise direction; otherwise, the brake will not work properly.



Always set the sectioning speed according to the hardness of the specimen! For hard specimens, always select a slow speed.

- Check the sectioning speed setting and set an appropriate speed.
- Start motorized sectioning.
- Pick up the sections and mount them on microscope slides.

## 5.9 Changing the specimen or interrupting sectioning



Lock the handwheel and cover the knife edge with the knife guard prior to any manipulation of knife or specimen head, as well as prior to changing the specimen block and during all work breaks!

- Raise the specimen to the upper end position and activate the mechanical handwheel lock.
- Cover the sectioning edge with the knife guard.
- Remove the specimen from the specimen clamp and mount a new sample to continue.
- Before cutting into a new specimen, move the specimen head back to the rear end position.



## 6. Optional Accessories

### 6.1 Assembly for fixture for specimen clamps



Depending upon the purchase order, the basic instrument is delivered with the directional or rigid fixture for specimen clamps which must be assembled first. All specimen clamps available as accessories can be used in both fixtures for specimen clamps.

**Before assembling the fixture for specimen clamps, activate the mechanical handwheel lock!**

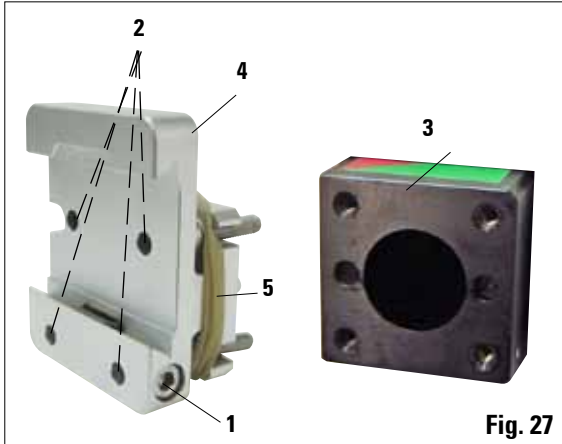

Fig. 27

#### 6.1.1 Rigid fixture for specimen clamps

- Screw the rigid fixture for specimen clamps (4) onto the specimen head (3): Remove the screw (1), place the specimen holder fixture (4) onto the specimen head (3) from the front and tighten the screws (2) with an Allen key No. 3. Next, insert the screw (1) from the side and briefly tighten it with an Allen key No. 4.



**Remove the rubber ring only after attaching the specimen head!**

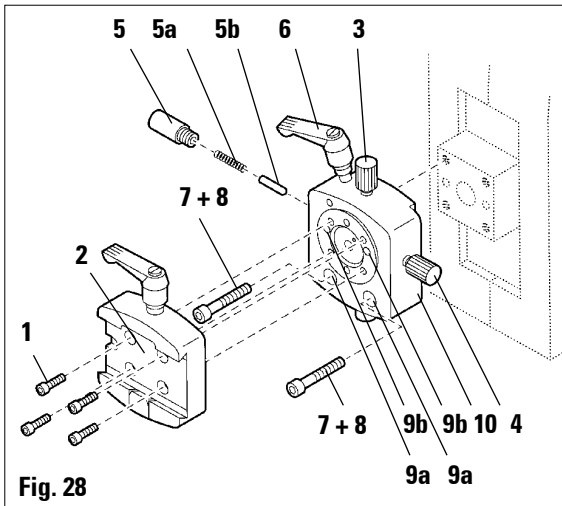
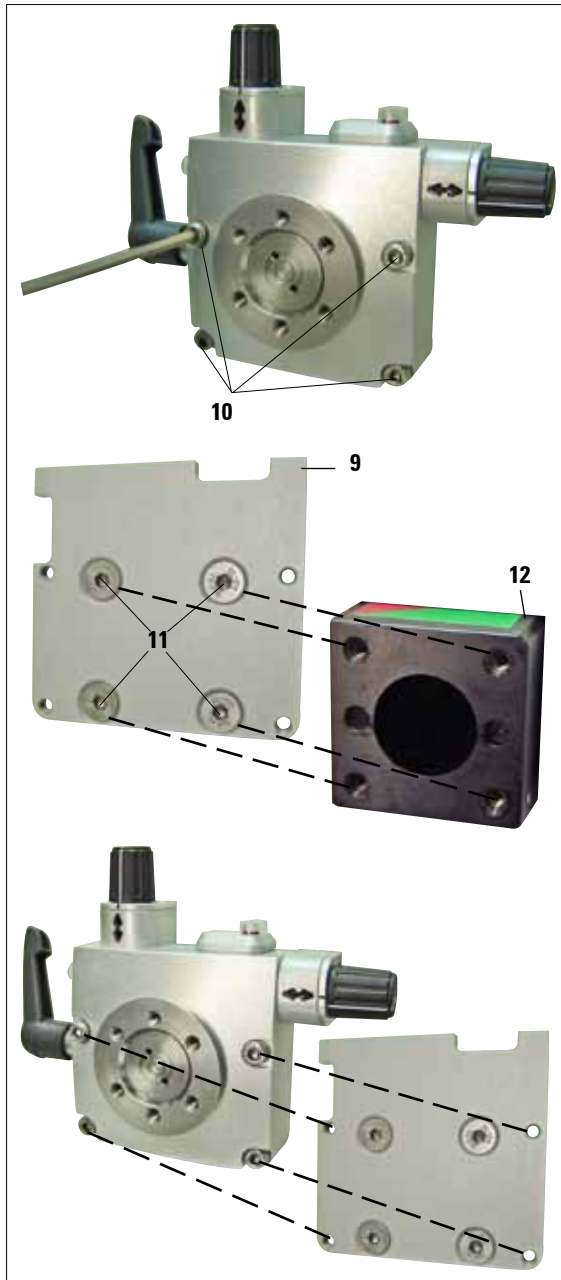

Fig. 28

- Finally, place the dovetail holder (2) and fasten by screwing in the 4 screws (1) using an Allen key No. 3.
- Loosen the eccentric bolt (6) by turning it counterclockwise.
- Completely unscrew the thrust piece (5) with a flat-tip screwdriver and pull it out with spring (5a) and pin (5b).
- Completely unscrew the setscrews (3) and (4).
- Attach the directional fixture for specimen clamps as shown.
- Insert the screws (7+8) in the bore (2 screws (8) are accessible through the bore (9a) and evenly screw them in using an Allen key No. 3.
- Insert the spring (5a) and pin (5b) with the flatter side into the thrust piece (5). Completely screw in the thrust piece with a flat-tip screwdriver.
- Completely screw in the setscrews (3+4).

### 6.1.3 Fine-directional fixture for specimen clamps

- Before the fine-directional fixture for specimen clamps can be mounted, loosen 4 screws (10) (Allen key No. 3) and carefully remove the fixture for specimen clamps from the baseplate (9).



- Using the 4 supplied screws (11) and the Allen key No. 3, fasten the baseplate to the specimen head (12).

- Now, screw the fine-directional fixture for specimen clamps with the 4 screws (10) and the Allen key No. 3 onto the specimen head.



**If the fine-directional fixture for specimen clamps is not used, retain the baseplate and 4 screws (11) together with the fine-directional fixture for specimen clamps!**

Fig. 29

## 6. Optional Accessories

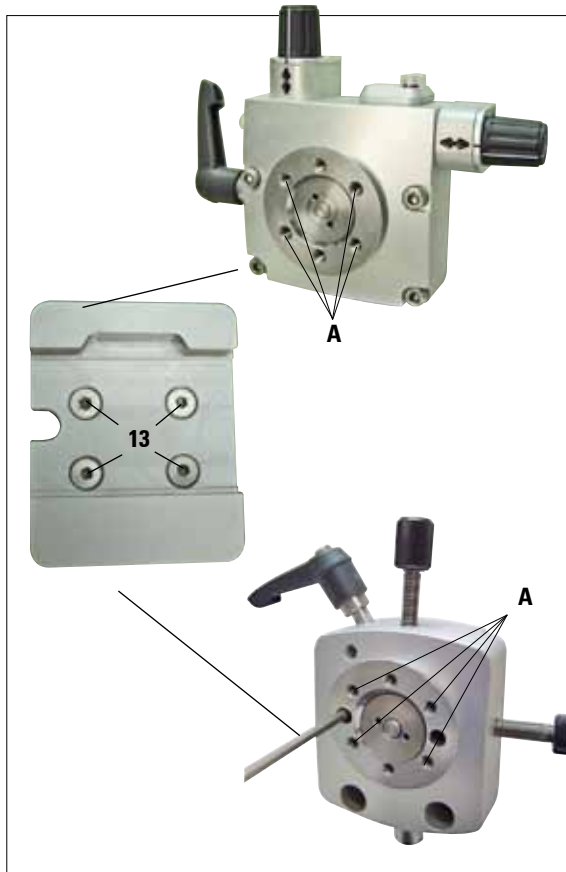

Fig. 30

### 6.1.4 Quick clamping system

It is used as a specimen holder for use with the fine-directional specimen holder fixture with zero point indicators or the directional specimen holder fixture.

- Screw the 4 screws (**13**) into bore **A** with an Allen key size 2.5 and tighten them.



### 6.1.5 Super mega-cassette clamp

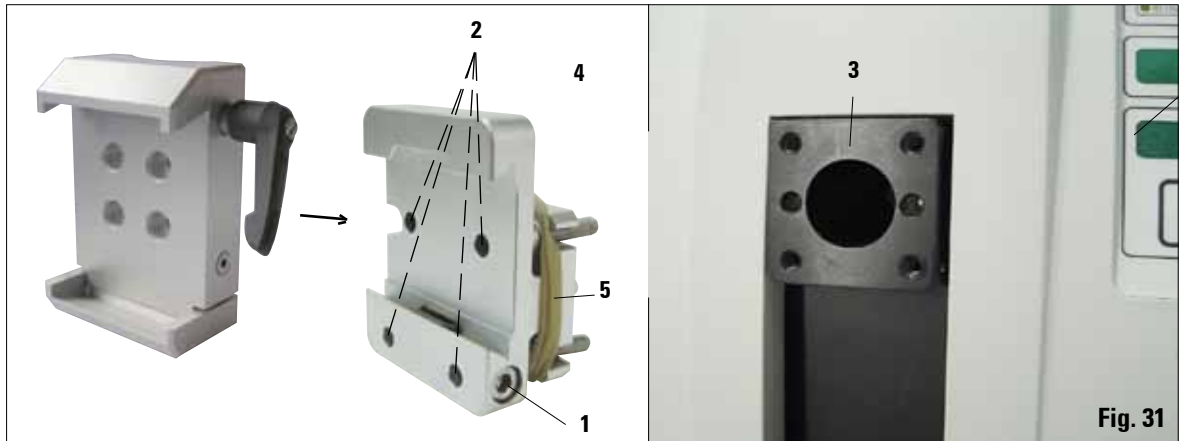

#### Assembly of the super mega-cassette clamp

The super mega cassette clamp should preferably be used with the rigid fixture for specimen clamps.

To do so, proceed as follows:



**Remove the rubber ring (5) only after having attached the cassette clamp on the specimen head!**

- Screw the rigid fixture for specimen clamps (4) onto the specimen head (3):  
Remove the screw (1), place the specimen holder fixture (4) onto the specimen head (3) from the front and tighten the screws (2) with an Allen key No. 3.  
Next, insert the screw (1) from the side and briefly tighten it with an Allen key No. 4.
- Insert the super mega-cassette clamp from the side on the left into the dovetail guide of the rigid fixture for specimen clamps and tighten screw (1).



**If the directional fixture for specimen clamps is used with the rigid knife holder base, the orientation must be in position "0" and the cover for backlighting illumination must be detached. (Danger of collision if not observed!)  
NEVER use the super mega-cassette clamp with backlighting illumination!**

## 6. Optional Accessories

### 6.2 Specimen clamps and holders



All specimen clamps available as accessories can be integrated into either the directional or non-directional specimen holder fixture.

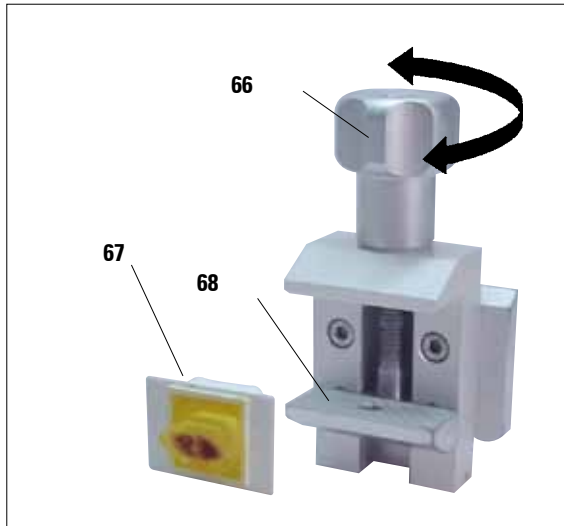

Fig. 32

#### 6.2.1 Standard specimen clamp

The standard specimen clamp is available in two sizes: 40 x 40 mm and 50 x 55 mm.

They are designed for direct clamping of rectangular blocks. In addition, they accommodate the foil clamps.

- Turn the knurled screw (**66**) counterclockwise to move the movable jaw (**68**) downward.
- Mount the specimen (**67**) as required.
- Turn the knurled screw (**66**) clockwise to move the movable jaw upward against the fixed jaw to securely clamp the sample.



When clamping cassettes, make sure that they are not clamped too tightly, since the cassette bodies can bend and result in sections that are too thick or thin, or the entire specimen may fall out and become damaged.

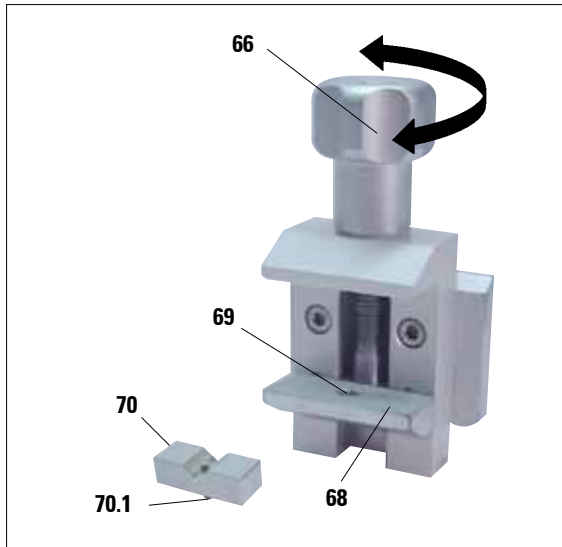

Fig. 33

### 6.2.2 Vee insert

The vee insert (**70**) is mounted in the hole provided in the lower movable jaw of the standard specimen clamp.

This makes it possible to clamp round specimens in the standard specimen clamp.

- Turn the knurled screw (**66**) counterclockwise to move the movable jaw (**68**) downward.
- Insert the pin (**70.1**) of the vee insert (**70**) in the hole (**69**) of the lower jaw (**68**).
- Mount the specimen as required.
- Turn the knurled screw (**66**) clockwise to move the movable jaw with the vee insert upward against the fixed jaw to securely clamp the sample.

## 6. Optional Accessories

### 6.2.3 Foil clamp type 1

The foil clamp type 1 is appropriate both for clamping very small and thin foil pieces and flat, angular specimens. It is mounted in the standard specimen clamp.

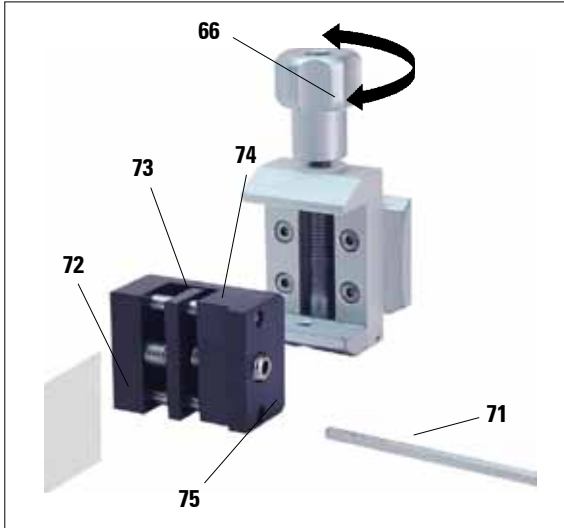

Fig. 34

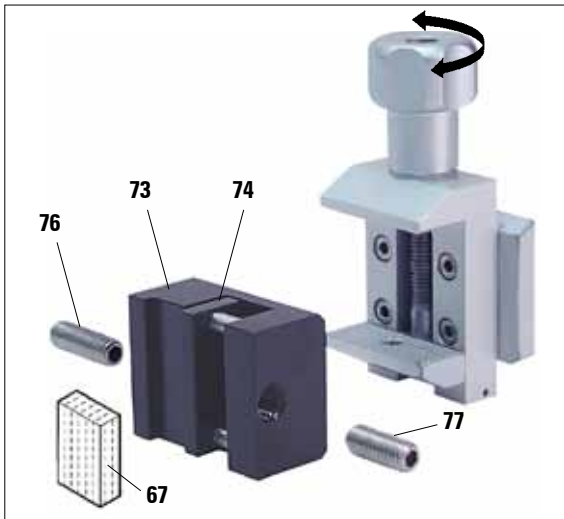

Fig. 35

### Clamping of foil pieces

- Move the movable jaw (74) to the right as required by turning the setscrew with an Allen key No. 4 (71).
- Place the foil (72) between the movable jaw (74) and the fixed jaw (73).
- To clamp the foil, screw the movable jaw (74) against the fixed jaw (73) by using the Allen key.
- Insert the foil clamp (75) in the standard specimen clamp as shown.
- Turn the knurled screw (66) clockwise to clamp the foil clamp in the standard specimen clamp.

### Clamping of flat, angular specimens

To clamp angular specimens, replace the long setscrew (76) with the short setscrew (77) provided with the foil clamp.

- Unscrew the long setscrew (76) to the left with an Allen key No. 4 (71).
- Screw the short setscrew (77) in the hole.
- Place the sample (67) between the movable jaw (74) and the fixed jaw (73).
- To clamp the sample, screw the movable jaw (74) by turning the setscrew (77) against the fixed jaw (73).
- Insert the foil clamp in the standard specimen clamp as shown.
- Turn the knurled screw (66) clockwise to clamp the foil clamp in the standard specimen clamp.

### 6.2.4 Universal cassette clamp

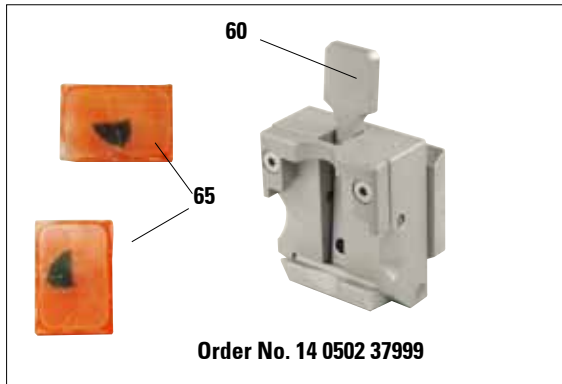

Fig. 36



Prior to sectioning, laboratory personnel **MUST** check that the cassette is seated securely in the universal cassette clamp.

- Push the lever (60) forwards.
- Mount the cassette (65) horizontally or vertically as required.
- To clamp the cassette, release the lever (60).



Leica / Surgipath cassettes with minimum dimensions of 39.8 x 28 mm and maximum dimensions of 40.9 x 28.8 mm may be clamped in the universal cassette clamp (UCC) horizontally as well as vertically.

When using other – particularly thin-walled – cassettes, the cassette may become deformed or other problems may arise with the clamping system. If the user tries clamping the cassette and realizes that it is not securely clamped into place, an alternative tensioning clamp must be used.

When using cassettes whose lid is molded on, make sure that the broken edge left by removing the lid does not prevent the specimen from being securely clamped – if necessary, the specimen must be clamped horizontally.

Before clamping the cassette into the universal cassette clamp, remove excess wax on the outside of the cassette to ensure that the cassette clamps in securely.

Wax deposits on the outside of the cassette can make the universal cassette clamp dirty. The dirt prevents the cassette from clamping in securely and can lead to sections being too thick or thin, chattering within the section and, in the worst-case scenario, damage to the specimen. Prior to sectioning, the user has to verify that the specimen is clamped securely and, if necessary, remove wax deposits from the universal cassette clamp according to the specifications in [Chapter 8.1 "Cleaning and maintenance – Universal cassette clamp"](#).

## 6. Optional Accessories

### 6.2.5 Holder for round specimens



The holder for round specimens is designed to accommodate cylindrical specimens. Inserts for specimens of 6, 15 and 25 mm diameter are available.

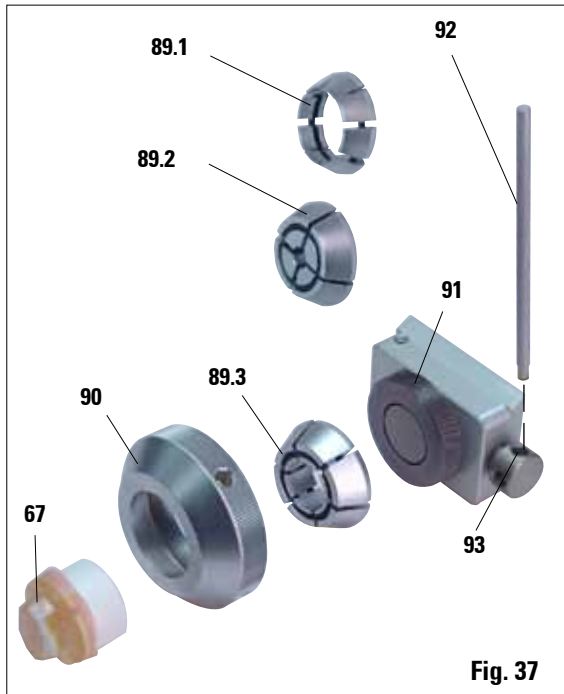

- To mount the required insert (**89.1-3**) turn the clamping ring (**90**) counterclockwise and remove.
- Place the required insert into the tension ring (**90**) and screw the tension ring onto the thread (**91**) by turning it clockwise.
- Mount the specimen (**67**) and clamp it by turning the clamping ring (**90**) clockwise.
- To orient the inserted specimen, insert the pin (**92**) into the bore (**93**) and rotate it counterclockwise to release the clamp. You can now rotate the specimen so that the side you want faces upwards.
- To lock it in the position you have chosen, tighten the pin (**92**) by turning it clockwise.

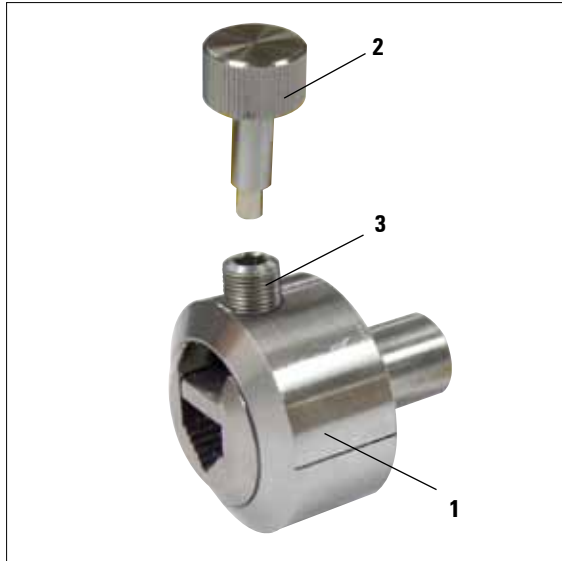

Fig. 38

### 6.2.6 Specimen holders

The specimen holders are especially intended for small specimens. They are available in two models: as an EM flat specimen holder (Fig. 41, 4) and an EM universal specimen holder (Fig. 40, 1). You can insert either specimen holder into the segment arc or the specimen holder fixture.

#### Clamping the specimens

- Insert the special key (2) into the clamping screw (3) of the specimen holder and open the clamping chucks of the specimen holder by turning the special wrench.
- Insert the specimen.
- Clamp the specimen by turning the special wrench.

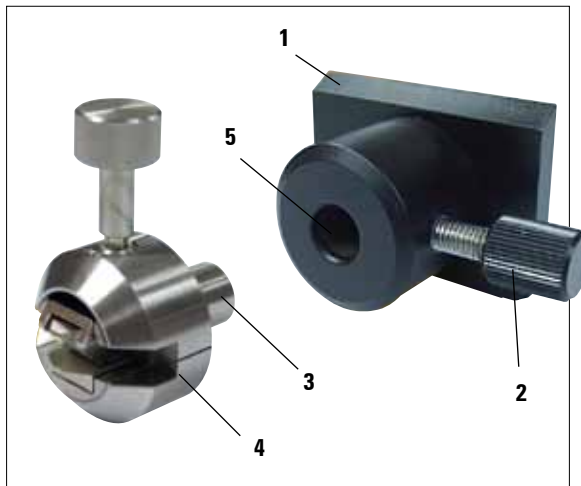

Fig. 39

### 6.2.7 Specimen holder fixture

The specimen holder fixture (1) is inserted into the dovetail fixture in the same way as a specimen clamp.

- Open the knurled screw (2) by turning it counterclockwise.
- Insert the pin (3) of the specimen holder (4) into the hole (5).
- Turn the knurled screw (2) clockwise to clamp the specimen holder.



If the backlighting illumination is used, ensure that the clamping screw is pointing up.

## 6. Optional Accessories

### 6.3 Knife holder base and knife holder



Fig. 40

#### 6.3.1 Knife holder base, without lateral displacement feature



Fig. 41

The plastic handles of all clamping levers on the instrument and knife holders can be moved to the position that is most convenient for each user. Pull the grip (94) out of the lever, hold it in this position, and rotate it to the desired position. It will then lock automatically when released.

#### Repositioning the knife holder base

The one-piece knife holder base (rigid) (51) can be moved forwards and backwards on the microtome base plate.

This vertical displacement allows bringing the knife holder into the optimal cutting position in relation to the specimen.

- To release, rotate the clamping lever (50) on the right side of the microtome base plate counterclockwise.
- Reposition the knife holder together with the knife holder base forward or backward as appropriate.
- Secure the clamping mechanism by rotating the lever (50) clockwise.



### 6.3.2 Knife holder E/E-TC



The knife holder E-TC is designed for the Leica TC-65 tungsten carbide blades.



Prior to inserting the blade, both knife holder and knife holder base must have been installed on the instrument!

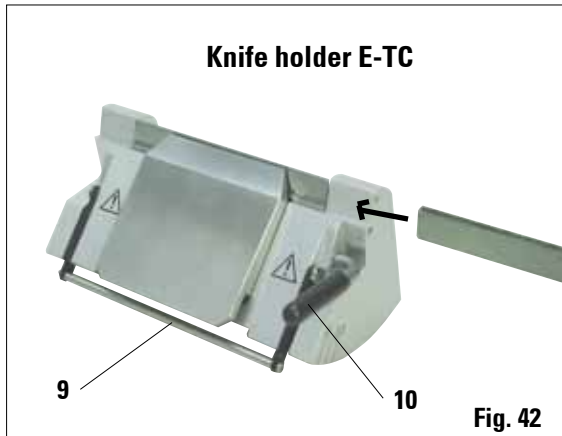

#### Inserting the blade, knife holder E and E-TC

- Fold knife guard (9) downward.
- To insert the blade, flip the right clamping lever (10) forward and down.
- Carefully insert the blade from the side. Make sure that the blade is clamped parallel to the upper edge of the pressure plate.
- To clamp the blade, rotate clamping lever (10) back upwards.



The knife holder E is designed for conventional disposable blades from all current manufacturers. It is available in two models: one for low-profile blades and one for high-profile blades. The knife holder has a lateral movement, so that the entire width of the blade can be used. It is also equipped with a blade ejector (9a).

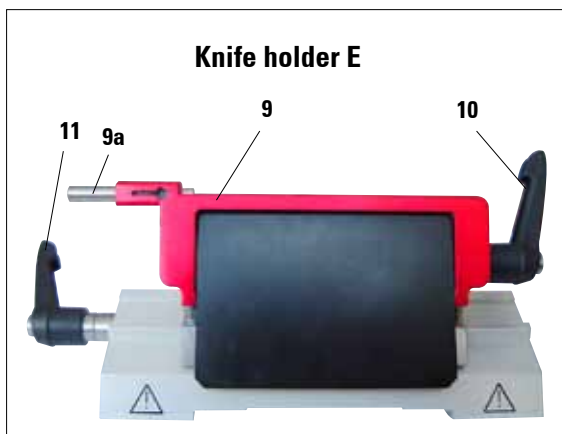

The clamping levers on the knife holder are not interchangeable. The two clamping levers (10, 11) must remain in the position shown at all times, as otherwise isolated malfunctions of the knife holder can occur.

Clamping lever for the blade (10) at the right, clamping lever for the lateral displacement (11) at the left.

## 6. Optional Accessories

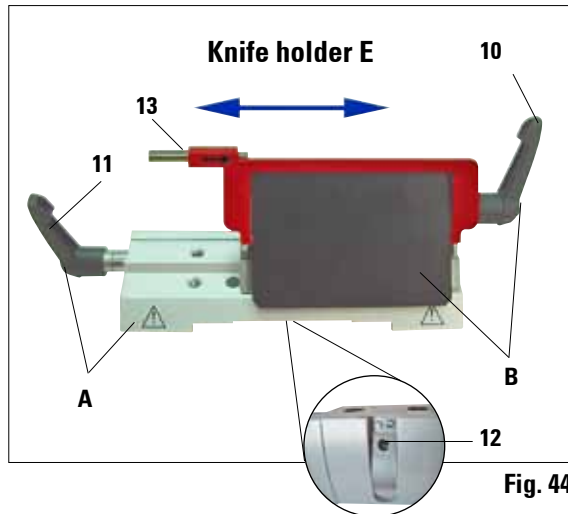

Fig. 44

### Lateral displacement (only for knife holder E)

The lateral displacement feature of the knife holder base enables the use of the entire length of the blade, eliminating the need for readjusting the knife holder. The knife holder E consists of a segment arch A (with lever (11)) and the clamp mount B (with lever (10) and ejector (13)).

The extreme left and right positions as well as the middle position are each marked with a click stop.

- To release the clamp, rotate the lever (11) on the left side of the knife holder forwards.
- Move the knife holder sideways.
- To clamp, rotate the lever (11) back.

### Note on the knife holder E:

The knife holder E is an important precision component, the quality and precise adjustment of which have a lasting effect on the entire function of the microtome. In case of malfunctions or damages to the clamp mount, it is always required to replace the clamp mount, including the pertinent clamping lever.

Leica Biosystems offers special prices for new clamp mounts in case of damages to the clamp mount after the warranty has expired.

In this way, perfect function of the device can be ensured over the course of many years.

### Setting of the clamping system of the clamp mount on the segment arch

To ensure a proper sectioning result, clamp mount B must be securely clamped onto segment arch A.

The clamping is carried out using an eccentric at the lever (11). The clamping force is adjusted with the setscrew (12) on the underside of the segment arch. The setting of the clamping is carried out so that the clamping lever can be rotated to the stop with constantly increasing resistance.

Adjust the clamping with a 2.5 mm Allen key at the setscrew (12) so that the lever initially "slips" when the lever is activated. Continue turning the grub screw (12) a little bit (approx.  $\frac{1}{4}$  turn to the left or right), then check that the lever no longer "bars", but also does not jam "heavily".

(The language CD features a short video film for this purpose.)

### Knife holder E with a water trough for low-profile blade

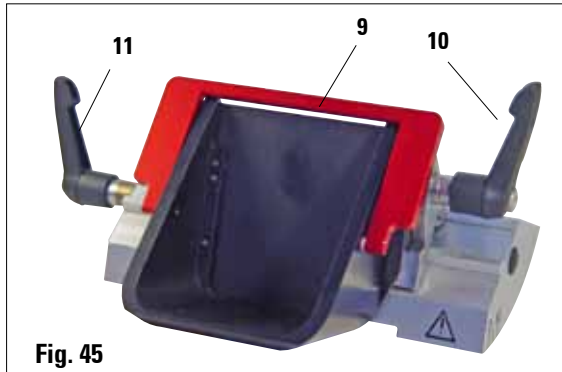

Fig. 45

The knife holder E with a water trough is for low-profile blades.

The knife guard on knife holder E consists of a red foldaway handle (9). To cover the cutting edge, fold the knife guard handle (9) upwards as illustrated in the figure.



**The clamping levers on the knife holder are not interchangeable. The two clamping levers (10 and 11) must remain in the position shown at all times, as otherwise isolated malfunctions of the knife holder can occur.**

**Clamping lever for the blade (10) at the right, clamping lever for the lateral displacement (11) at the left.**

#### Use

Floating thin paraffin sections (for example, for subsequent immunostaining procedures) on the surface of the water. Flat paraffin sections can be removed from the surface of the water using glass slides.



Fig. 46

The vessel is filled with water up to the blade. After trimming, remove the section waste from the tray and create the sections to be prepared. The sections floating on the surface of the water can be removed using the glass slide.

## 6. Optional Accessories

### 6.3.3 Knife holder N/NZ



The knife holders N and NZ are appropriate for standard steel and tungsten carbide knives, profile c and d, up to 16 cm long. The integrated height adjustment feature allows you to also use knives that have been resharpened numerous times.

#### Mounting the knife support bar

- Push knife guard (8) to the center.
- Set the knife support bar (46) onto the height adjustment screws (not visible) in the position shown. The flat ends of the height adjustment screws must be located in the slots at each end of the knife support bar.



**Prior to inserting the knife, both knife holder and knife holder base must have been installed on the instrument!**

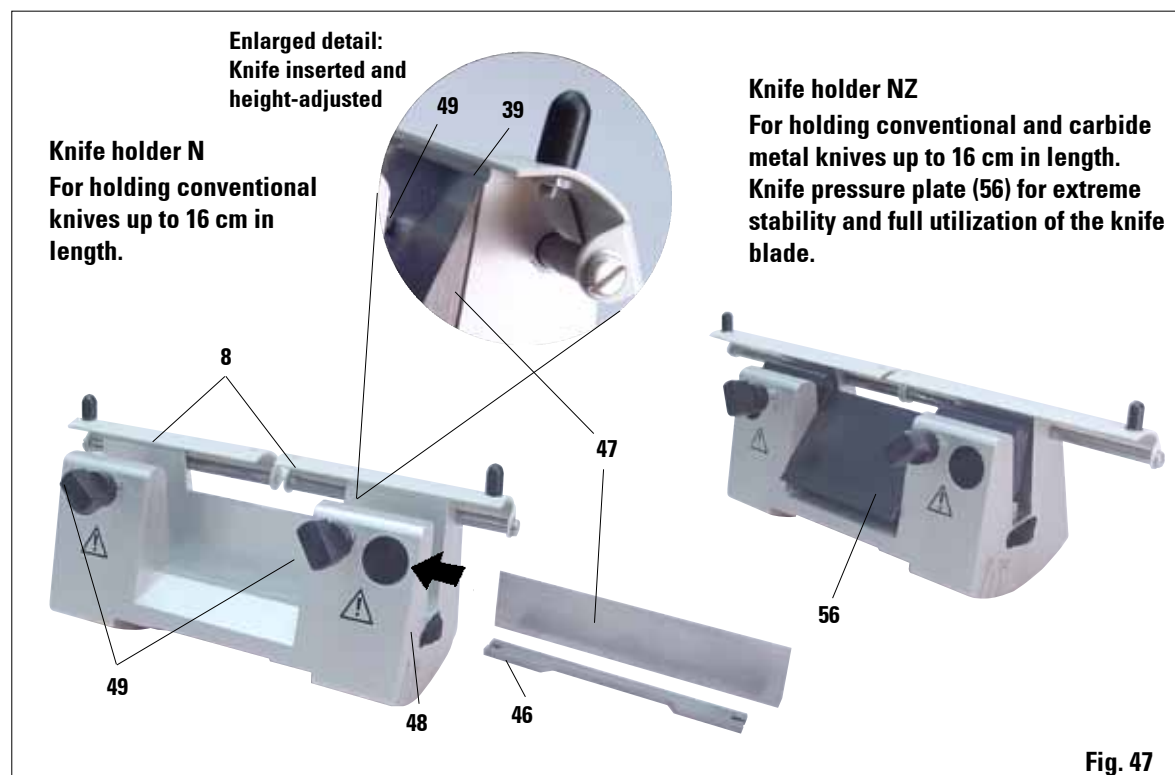

Fig. 47

### Inserting the knife

- Rotate the knurled nuts **(48)** on the right and left of the knife holder forward in opposite directions, lowering the knife support bar to the lowest possible position, thus ensuring that the knife edge will not be damaged when inserting the knife.
- Unscrew the clamping screws **(49)** as far out as possible (rotate counterclockwise).
- Hold the knife **(47)** at the knife base and carefully insert it in the holder from the side as shown with the cutting edge facing upward.

### Knife height adjustment

When adjusting the clearance angle, the knife edge should be positioned as exactly as possible in the actual center of rotation of the knife holder. The lay-on edge **(39)** of the rear clamping chucks serves as a reference position for correct knife height adjustment. The knife edge should be parallel with the locating edges.

- Rotate the knurled nuts **(48)** uniformly and backwards until the knife blade is parallel to the lay-on edge **(39)** ([see detailed illustration](#)) of the rear clamping chucks.
- To clamp the knife **(47)** evenly screw the two knife clamping screws **(49)** inward (rotate clockwise).

### Lateral repositioning of the knife

- Push knife guard **(8)** to the center.
- Loosen the clamping screws **(49)** by turning them counterclockwise.
- Push the knife **(47)** to the left or right as required.
- To clamp the knife **(47)**, always tighten the clamping screw **(49)** first which is located on the side to which the knife has been repositioned by turning it clockwise.

## 6. Optional Accessories

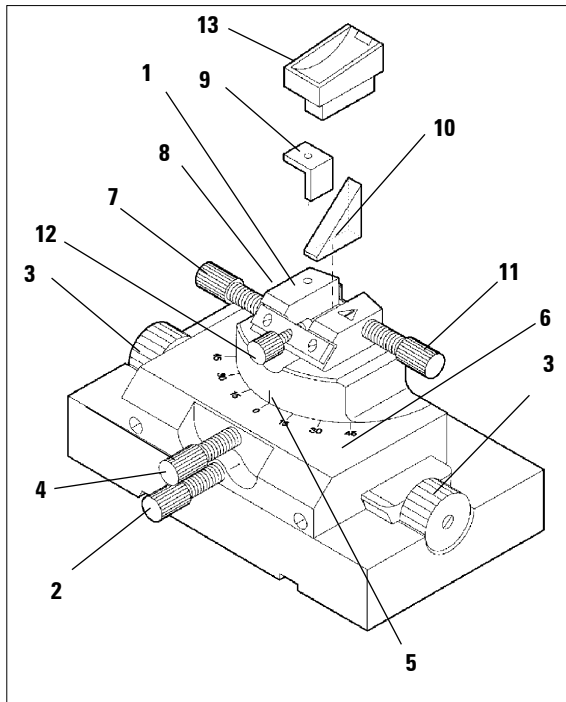

Fig. 48

### Rotating the upper part by 45°

- Loosen the screw (4).
- Set the index mark (5) of the upper part to the desired value on the scale (6).
- Retighten the screw (4).

### Adjusting the clearance angle

- Loosen the screw (7).
- Using the clearance angle scale to the left of the insert (8, not visible here), move the insert (1) to the desired value.
- Retighten the screw (7).

### 6.3.4 Knife holder GD

The knife holder GD is designed for glass and diamond knives. It is delivered with its own base and thus cannot be used with the universal knife holder base.

The knife holder GD is attached to the baseplate and clamped like the universal knife holder base. Several adjustments options are provided for this knife holder. The entire insert (1) can be removed and exchanged for other inserts.

#### East/west movement

- Loosen the screw (2).
- To move the upper part towards the right, turn the rotary knobs (3) clockwise; to move it towards the left, turn them counterclockwise.
- Retighten the screw (2).

#### Insert for triangular glass knives

The insert for triangular glass knives (10) is designed for glass knives with a width from 6 to 12 mm. The angle insert (9) is used in combination with 6 mm wide knives.

- Loosen the screw (11).
- Insert the angle insert (9) as shown.
- Insert the glass knife (10) as shown and clamp it with the screw (11).
- To stabilize the knife when sectioning, gently tighten the screw (12).

#### Inserting diamond knives

The insert (1) can also be used for diamond knives with a water bath (13).

- Loosen the screw (11).
- Insert the diamond knife (13) as shown and clamp it with the screw (11).
- Gently tighten the screw (12).

6.4 Blades/knives

6.4.1 Disposable blades



Fig. 49

**Disposable blades - low profile (819)**

80 x 8 x 0.25 mm

01 package of 50 pcs. .... 14 0358 38925

10 packages of 50 pcs. .... 14 0358 38382



Fig. 50

**Disposable blades - high-profile (818)**

80 x 14 x 0.35 mm

01 package of 50 pcs. .... 14 0358 38926

10 packages of 50 pcs. .... 14 0358 38383

6.4.2 Knife

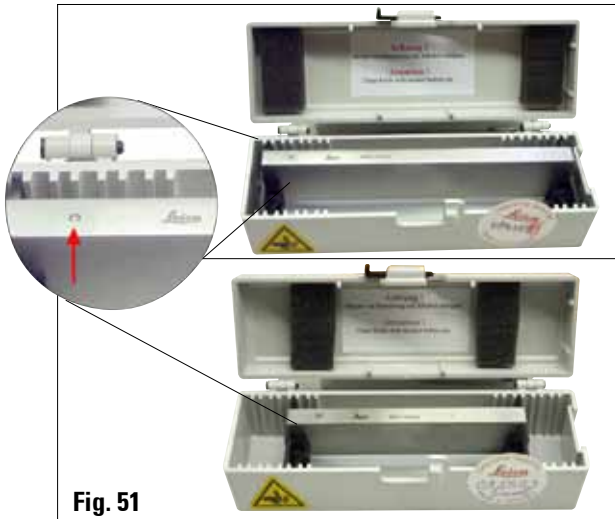

Fig. 51

**Knife 16 cm - profile c - steel**

Knife, 16 cm long, profile c (ground on both sides, for paraffin and frozen sections)

Note: Knife case 14 0213 11140 included

Order No. .... 14 0216 07100

## 6. Optional Accessories



### Knife 16 cm, profile d - steel

Knife, 16 cm long, profile d

Note: Knife case 14 0213 11140 included

Order No. .... 14 0216 07132

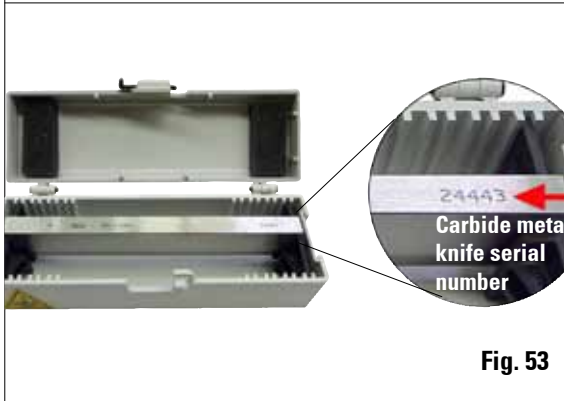

### Knife, 16 cm, profile d, tungsten carbide

Knife, 16 cm long, tungsten carbide, profile d

Note: Knife case 14 0213 11140 included

Order No. .... 14 0216 04813

### Knife 16 cm, profile c, tungsten carbide

Knife, 16 cm, tungsten carbide, profile c

Note: Knife case 14 0213 11140 included

Order No. .... 14 0216 04206



### Knife case

Variable knife case (plastic),  
for 1 or 2 knives: 10 - 16 cm long

(Carbide metal or SM2500 knife: only for 1 knife!)

Order No. .... 14 0213 11140



### 6.5 Section waste tray

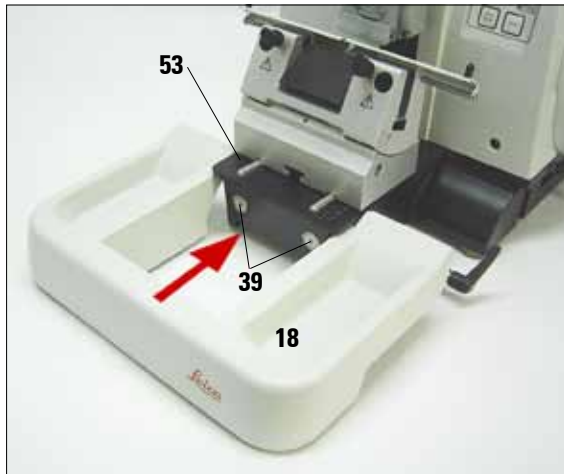

Fig. 55

- Push the section waste tray (18) from the front to the microtome base plate (53) until it is held in place by the two magnets (39) (on the front of the microtome base plate).  
To remove the section waste tray, lift it slightly and pull it off towards the back.

### 6.6 Backlighting

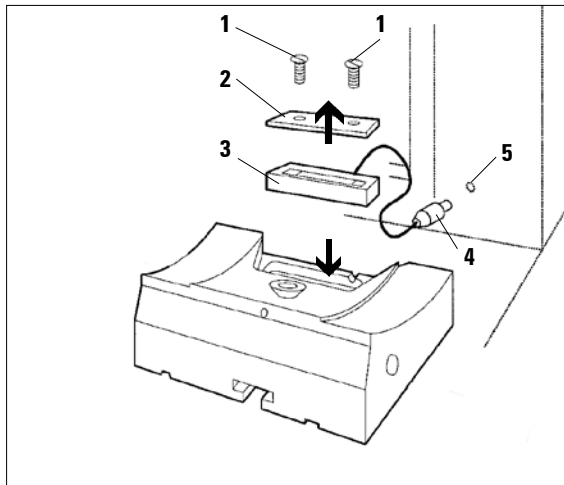

Fig. 56



The backlighting is inserted into the front of the one-piece knife holder base.

- Remove the two screws (1) using a slotted screwdriver and then remove the cover plate (2).
- Insert the backlighting (3) in the recess at the rear of the knife holder base.
- Connect the plug (4) of the backlighting to the socket (5) on the microtome.

The backlighting illuminates once the microtome is turned on with the power switch.



**NEVER** use the backlighting illumination with the super mega-cassette clamp!

## 6. Optional Accessories

### 6.7 Freezer pack

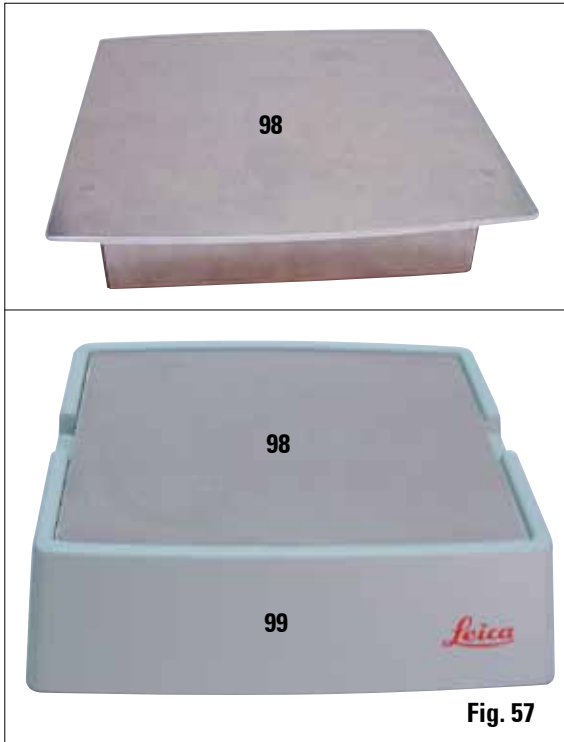

Fig. 57

The freezer pack consists of the freezer plate (98) and the insulation jacket (99). It is for cooling (or keeping cold) paraffin specimens. Up to 35 standard cassettes can be cooled at the same time. The specimens require approx. 20 min. for being cooled from room temperature (approx. 20 °C) to "sectioning temperature".

The cooling performance depends on the ambient temperature and the volume of the specimens being cooled.

The insulation jacket can be placed on the hood of the microtome in the same manner as the tray, or it can be placed next to the instrument.

- Remove the freezer plate from the insulation jacket and place it in a deep freezer, ideally overnight (but for at least six hours) at approx. -23 °C.
- Reassemble the freezer plate and insulation jacket and place them on the bench or the instrument.

### 6.8 LN22



Fig. 58 - LN22 (on Leica RM2265)

The Leica LN22 liquid nitrogen freezing attachment has been developed to switch back and forth between sectioning at room temperature and frozen section applications quickly and without problems.

#### Instrument characteristics:

Cryogenic chamber accessible from above - cooled with liquid nitrogen - for creating frozen sections in a condensate and ice-free chamber at temperatures up to -150 °C. Backlighting, knife holder etc. . .

### 6.9 Universal microscope carrier

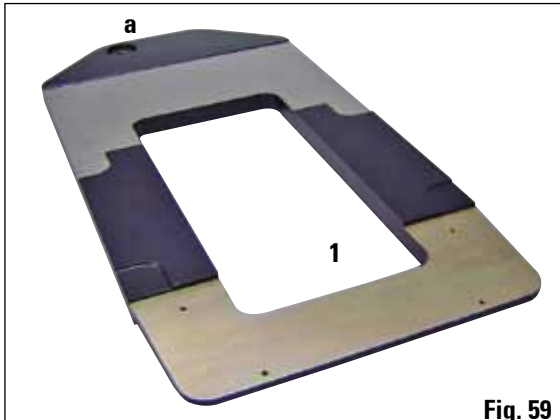

Fig. 59

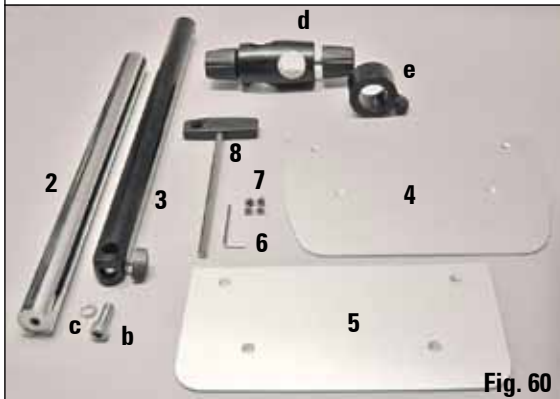

Fig. 60

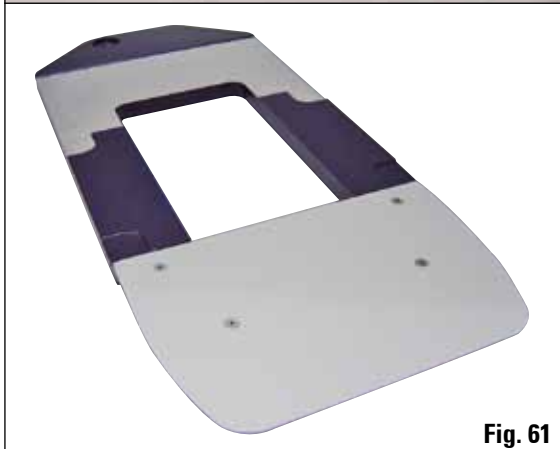

Fig. 61



- 1 - Baseplate with drilling (a)
- 2 - Vertical column with size 8 cap screw (b) and lock washer (c)
- 3 - Horizontal arm with cross-member (d) and support ring (e)
- 4 - Support plate, large (for RM2235, RM2245 and RM2255)
- 5 - Support plate, small (for RM2265)
- 6 - Allen key, size 3
- 7 - 4 countersunk screws to install support plate
- 8 - Allen key, size 8

#### Assembling the universal microscope carrier

1. **Attach baseplate**
  - Select the large (5) or small (4) support plate, depending on the microtome to be used.
  - Attach the support plate to the baseplate with the included 4 countersunk screws (7) using the Allen key No. 3 (6).

## 6. Optional Accessories

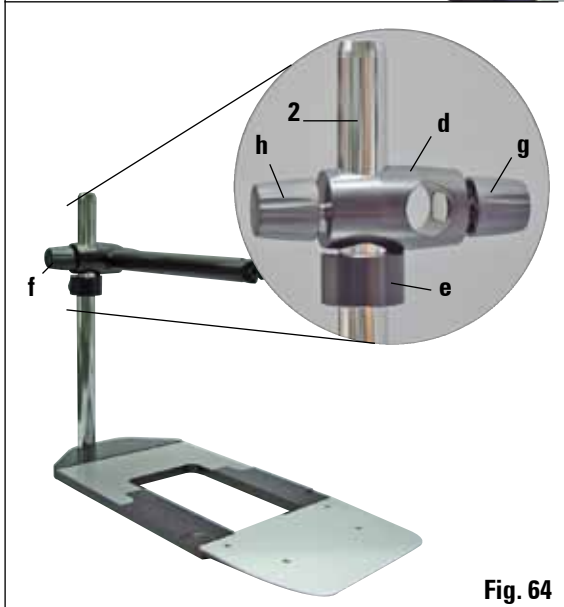
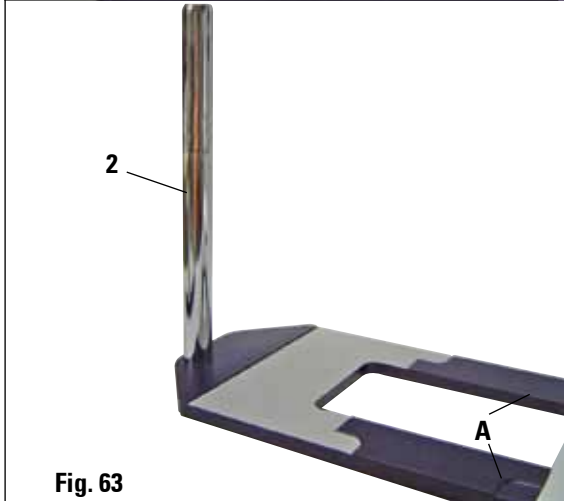
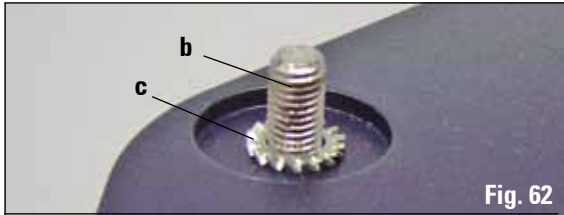

### 2. Attach vertical column

- Insert the cap screw (b) into the hole of the baseplate from below. Place the lock washer (c) on the cap screw from above.
- Thread the silver vertical column (2) onto the baseplate from above and tighten with the Allen key size 8.



The lock washer must be positioned between the baseplate and vertical column to prevent unintentional turning of the column.



Extreme danger of tipping! After installing the vertical column, immediately place the microtome onto the baseplate so that the front feet of the microtome are positioned in the shallow recesses (A).

### 3. Attach horizontal arm

- Slide the support ring (e) onto the vertical column and position it so that the lock nut (f) is facing to the back. Tighten the lock nut.
- Slide the cross-member (d) onto the column. Ensure that the lock screw (g) is facing to the right of the baseplate. The horizontal arm must be centered over the microscope.
- Slide the horizontal arm (3), flat side facing the lock screw (g), into the cross-member (d) and tighten.



For more information on connecting and using the microscope, magnifying lens or cold-light source, please see the appropriate Instructions for Use.

### 6.10 Magnifying lens



Fig. 65



Fig. 66



Fig. 67



The magnifying lens provides a 2x magnification and can be used with all Leica 2200 series rotary microtomes.

- Open the screw (3) on the horizontal arm of the microscope carrier in a counterclockwise direction.
- Insert the silver connection piece (1) as far as it will go. Tighten the screw (3).
- The adapter (2) allows a fiber-optic light guide to be installed.
- The instrument illustrations in [Fig. 70](#) and [Fig. 71](#) are an example only.
- Adjust the position of the magnifying lens to the specimen being processed. The magnifying lens can be swiveled completely to the side if necessary.



Always protect the magnifier glass from exposure to direct sunlight! Exposure to sunlight may cause a burning glass effect. Danger of fire!

- Use the provided protective cap (4) to cover the magnifying lens.

## 6. Optional Accessories

### 6.11 Cold light source



Fig. 68



The cold light source may be operated at the power supply voltage specified on the identification label (on the underside of the instrument) only.

- Connect the power cable (1) to the connecting jack on the rear of the device.
- Plug the power plug into the power socket.



Before use, carefully read the separately provided Instructions for Use!

### 6.12 Fiber-optic light guide

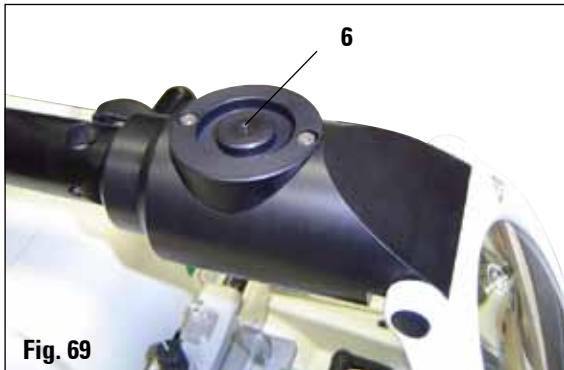

Fig. 69



Fig. 70



Fig 71, Leica rotary microtome with installed optional accessories: Magnifier and fiber-optic light guide

**6.13 Ordering information**

Fixture for specimen clamps, rigid, silver .....	14 0502 38160
Fixture for specimen clamps, directional, silver .....	14 0502 38949
Fixture for specimen clamps, directional, with 2 zero point indicators, silver.....	14 0502 37717
Quick clamping system, complete.....	14 0502 37718
Knife holder-base rigid, silver .....	14 0502 37962
Knife holder N RM2200, silver .....	14 0502 37993
Knife holder NZ RM2200, silver .....	14 0502 37994
Knife holder E low profile RM2200, silver, with ejector .....	14 0502 40508
Knife holder E high profile RM2200, silver, with ejector .....	14 0502 40509
Knife holder E, with a water trough for low-profile blades RM2200.....	14 0502 38961
Knife holder E-TC RM2200 silver.....	14 0502 37997
Knife holder GD RM2200, silver, for glass and diamond knife .....	14 0502 39052
Low-profile disposable blades, Type 819 (80x8x0.25 mm), 1x50 .....	14 0358 38925
High-profile disposable blades, Type 818 (80x14x0.35 mm) 1x50 .....	14 0358 38926
Knife 16 cm profile C, steel .....	14 0216 07100
Knife 16 cm profile D, steel .....	14 0216 07132
Knife 16 cm, TC-edge, profile D.....	14 0216 04813
Knife 16 cm, TC-edge, profile C.....	14 0216 04206
Knife holder case (plastic), variable width 10-16 cm .....	14 0213 11140
Standard specimen clamp with adapter 40x40, silver .....	14 0502 37998
Standard specimen clamp with adapter 50x55, silver .....	14 0502 38005
V-insert for Standard specimen clamp, silver.....	14 0502 38000
Universal cassette clamp with adapter (silver) .....	14 0502 37999
Megaclamp assembly RM2200, silver .....	14 0502 38967
Foil clamp - type 1, black.....	14 0402 09307
Round specimen holder with adapter and 3 clamping rings, silver.....	14 0502 38002
Segment arch, with adapter, indirect .....	14 0502 29969
Segment arch, with adapter, direct .....	14 0502 40314
EM specimen holder fixture, black.....	14 0502 29968
EM univ. specimen holder .....	14 0356 10868

## 6. Optional Accessories

---

EM flat specimen holder .....	14 0355 10405
Special wrench f. EM holder .....	14 0356 10869
Backlighting assembly .....	14 0502 38719
Foot switch .....	14 0502 38257
Cooling device assembly .....	14 0502 38325
Section waste tray .....	14 0502 37931
Section waste tray RM2265 .....	14 0503 39060
Universal microscope carrier .....	14 0502 40580
Magnifying lens assembly .....	14 0502 42790
Cold light sources	
Leica CLS 100X, 100-120 V/50-60 Hz.....	14 0502 30214
Leica CLS 100X, 230 V/50-60 Hz.....	14 0502 30215
Leica CLS 100X, 240 V/50-60 Hz.....	14 0502 30216
Fiber-optic light guide.....	14 0502 30028
Demo Box RM2200 series .....	14 0502 38930
"Leica" brush w/magnet.....	14 0183 40426
LN22.....	14 0378 39166



### 7.1 Instrument malfunctions



Certain instrument malfunctions appear on the 3-digit LED display or are indicated through illuminated LED's on the control panel.

#### 7.1.1 Error reports



If the message "E 1" follows the software version indication after switching on the instrument, a loss of parameters has occurred.

- Press any key.
- All parameters are then set back to the default values.
- Now all settings must be checked to see if the values are still correct. The values may have to be reentered.

You can continue with your normal working routine.

#### 7.1.2 Malfunctions, possible causes and troubleshooting



The following is a list of the most common problems which can arise while working with the instrument, along with possible causes and troubleshooting procedures. If the malfunction cannot be remedied with any of the options listed in the table, or the problem occurs repeatedly, inform Leica Service Support immediately.

Problem	Possible cause	Corrective action
<ul style="list-style-type: none"> <li>• <b>No display; no reaction to buttons pressed after the instrument is switched on.</b></li> </ul>	<ol style="list-style-type: none"> <li>1. The power cable is not connected correctly.</li> <li>2. Power fuses are defective.</li> <li>3. The cable of the control panel is not connected correctly.</li> <li>4. The voltage selection switch is set incorrectly.</li> </ol>	<ol style="list-style-type: none"> <li>1. Check the connection of the power cable.</li> <li>2. Replace the power fuses. (see <a href="#">Chapter 8.2.1</a>)</li> <li>3. Check the connection of the cable to the control panel.</li> <li>4. Check the voltage setting and correct it if necessary (see <a href="#">Chapter 4.5</a>)</li> </ol>

## 7. Troubleshooting

Problem	Possible cause	Corrective action
<ul style="list-style-type: none"> <li>The cutting motor cannot be started.</li> </ul>  <p style="text-align: center;">Fig. 72</p>	<ol style="list-style-type: none"> <li>The <b>EMERGENCY STOP</b> button is pressed or the foot switch is depressed.</li> <li>The handwheel lock is activated.</li> <li>The motor was temporarily overloaded and was switched off via the automatic fuse.</li> <li>The foot switch or dummy plug is not connected or not connected correctly.</li> </ol>	<ol style="list-style-type: none"> <li>Unlock the <b>EMERGENCY STOP</b> button and select the operating mode; release the foot switch.</li> <li>Release the handwheel lock.</li> <li>Switch off the instrument and wait 30 seconds. Push the button of the automatic fuse (<b>28</b>) on the rear of the instrument. Switch the instrument back on.</li> <li>Connect the foot switch or dummy plug and ensure that it is connected correctly.</li> </ol>
<ul style="list-style-type: none"> <li>Feed motion no longer occurs. The cutting motor cannot be started.</li> </ul>	<ol style="list-style-type: none"> <li>The end of the residual path has been reached.</li> <li>The specimen was already within the residual path when the instrument was switched on.</li> </ol>	<ol style="list-style-type: none"> <li>Select the trim mode by pressing <b>TRIM/SECT</b>. Then retract the specimen using the coarse feed button.</li> <li>Follow the procedure in Item 1.</li> </ol>
<ul style="list-style-type: none"> <li>The coarse feed buttons can be used to move the object in a backwards direction only.</li> </ul>	<ol style="list-style-type: none"> <li>The motorized sectioning process is still in progress.</li> </ol>	<ol style="list-style-type: none"> <li>End motorized sectioning by pressing the foot switch or the <b>RUN/STOP</b> or <b>ENABLE</b> button.</li> </ol>
<ul style="list-style-type: none"> <li>The specimen in the residual path area cannot be returned using the coarse feed buttons.</li> </ul>	<ol style="list-style-type: none"> <li>The <b>STEP</b> mode is still active (LED in <b>SECT</b> button lights up).</li> </ol>	<ol style="list-style-type: none"> <li>Press the <b>TRIM/SECT</b> button to switch to trimming mode. Return the specimen using the coarse feed button.</li> </ol>
<ul style="list-style-type: none"> <li>Cutting motor switches off prematurely in <b>CONT</b> (continuous stroke) operating mode.</li> </ul>	<ol style="list-style-type: none"> <li>Foot switch was held down too long when starting the sectioning process.</li> <li>The <b>RUN/STOP</b> and <b>ENABLE</b> buttons of the control panel were not released simultaneously after starting.</li> </ol>	<ol style="list-style-type: none"> <li>Only press the foot switch briefly to start the sectioning process.</li> <li>Release both buttons simultaneously.</li> </ol>
<ul style="list-style-type: none"> <li><b>HOME</b> and <b>STOP</b> are lit up simultaneously.</li> </ul>	<ol style="list-style-type: none"> <li>The end position detection is defective.</li> </ol>	<ol style="list-style-type: none"> <li>Contact Leica after-sales service.</li> </ol>

Problem	Possible cause	Corrective action
<b>7.2 Possible faults</b>		
<p><b>1. Thick/thin sections</b></p> <p>The sections alternate between being thick and thin, or there is chattering in the sections, or the specimen is torn out of the embedding. In extreme cases, there are no sections whatsoever.</p>	<ul style="list-style-type: none"> <li>Blade, knife holder or orientation is not clamped properly.</li> </ul>	<ul style="list-style-type: none"> <li>Reclamp the blade, knife holder or orientation.</li> </ul>
	<ul style="list-style-type: none"> <li>The specimen is not clamped properly.</li> </ul>	<ul style="list-style-type: none"> <li>Check that the cassette is securely clamped in the universal cassette clamp.</li> <li>If the universal cassette clamp is soiled by wax, clean the UCC (refer to <a href="#">Chapter 8.1 - "Cleaning and Maintenance - Universal cassette clamp"</a>).</li> <li>When using cassettes whose lid is molded on, check that the broken edge allows the cassette to be clamped securely; if necessary, remove burrs or clamp the cassette into the universal cassette clamp horizontally instead of vertically.</li> <li>If the cassette dimensions are within the specified tolerances and the cassette still cannot be securely clamped into place, it may be that the universal cassette clamp is configured incorrectly or is defective. In this case, have Technical Service inspect and reconfigure the universal cassette clamp.</li> </ul>

## 7. Troubleshooting

---

---

Problem	Possible cause	Corrective action
		<ul style="list-style-type: none"><li>• When using cassettes, particularly thin-walled cassettes, from a company other than Leica or Surgipath, the cassette may become deformed or other clamping problems may arise. If while trying to clamp the cassette you realize that it is not securely clamped into place, an alternative tensioning clamp must be used.</li></ul>
	<ul style="list-style-type: none"><li>• The blade is dull.</li><li>• The pressure plate is damaged or incorrectly adjusted.</li><li>• Clearance angle of the knife/blade too small.</li></ul>	<ul style="list-style-type: none"><li>• Laterally displace the knife holder or insert a new blade.</li><li>• Insert a new pressure plate or use a new knife holder.</li><li>• Methodically experiment with larger clearance angle settings until you have found the optimum angle.</li></ul>
<b>2. Section compression</b> The sections are very compressed, show folds or are squeezed together.	<ul style="list-style-type: none"><li>• The blade is dull.</li><li>• The specimen is too warm.</li><li>• The sectioning speed is too fast.</li></ul>	<ul style="list-style-type: none"><li>• Use another area of the blade or a new blade.</li><li>• Cool the specimen before sectioning.</li><li>• Reduce the sectioning speed.</li></ul>
<b>3. "Stripes" in sections</b> For knife holder E	<ul style="list-style-type: none"><li>• There is an accumulation of paraffin on the rear pressure plate of the knife holder.</li></ul>	<ul style="list-style-type: none"><li>• Remove paraffin from this area on a regular basis.</li></ul>

<b>Problem</b>	<b>Possible cause</b>	<b>Corrective action</b>
<b>4. Noises during sectioning</b> The knife "sings" when sectioning hard specimens. The sections show scratches or chatter marks.	<ul style="list-style-type: none"><li>• The sectioning speed is too fast.</li><li>• The clearance angle is too wide.</li><li>• Insufficient clamping of specimen clamp and/or knife holder.</li></ul>	<ul style="list-style-type: none"><li>• Select a slower sectioning speed.</li><li>• Methodically reduce the clearance angle setting until you have found the optimum angle.</li><li>• Check all screw and clamp connections on the specimen holder system and the knife holder. If necessary, tighten the levers and screws.</li></ul>
<b>5. High blade consumption</b>	<ul style="list-style-type: none"><li>• Too great of a sectioning force was applied.</li></ul>	<ul style="list-style-type: none"><li>• Adjust the sectioning speed and/or section thickness when sectioning. Select a thinner section.</li></ul>

## 8. Cleaning and Maintenance

---

### 8.1 Cleaning the instrument



**Before each cleaning, carry out the following preparatory steps: Always remove the knife / blade before detaching the knife holder from the instrument.**

**Always put the knives back into the knife case when not in use!**

**Never place a knife anywhere with the cutting edge facing upwards and never try to catch a falling knife!**

**When using cleaning agents, observe the manufacturer's safety instructions and the laboratory regulations valid in the country of use.**

**When cleaning the outer surfaces, do not use xylene, scouring powders or solvents containing acetone or xylene. Acetone or xylene will damage the finished surfaces!**

**Ensure that liquids do not enter the interior of the instrument during cleaning!**

- Raise the specimen clamp to the upper end position and activate the handwheel lock.
- Switch the unit off and unplug it.
- Remove the blade from the knife holder and insert it in the receptacle at the bottom of the dispenser, or remove the knife from the knife holder and put it back in the knife case.
- Remove knife holder base and knife holder for cleaning.



**Never place blade or knife holders with/without base close to the edge of the table to prevent them from falling down.**

- Remove the specimen from the specimen clamp.
- Remove section waste with a dry brush.
- Remove specimen clamp and clean separately.

#### Instrument and outside surfaces

If necessary, the varnished outside surfaces of the control panels can be cleaned with a mild commercial household cleaner or soap water and then be wiped with a moist cloth.

To remove paraffin residue, xylene substitutes, paraffin oil, or paraffin removers such as "Para Gard" (Polysciences) can be used.

The instrument must be completely dry before it can be used again.

#### Cleaning the knife



**Always wipe the knife from the back of the knife to the cutting edge. NEVER wipe in the opposite direction - risk of injury!**

Clean using an alcohol-based solution or acetone.

## 8. Cleaning and Maintenance

### Knife holder E

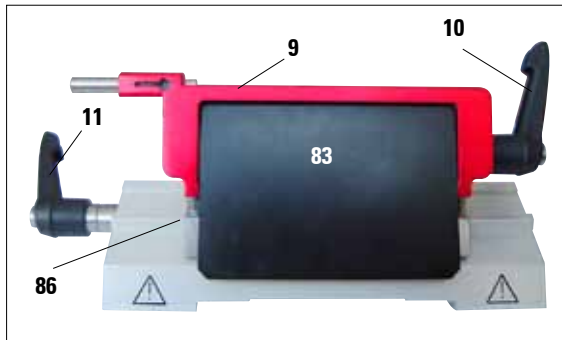

Fig. 73

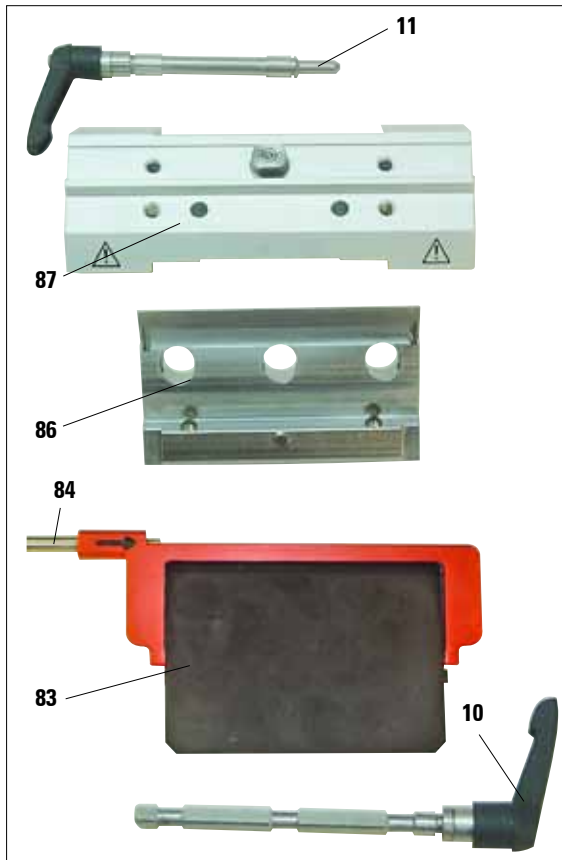

Fig. 74

Take the knife holder apart for cleaning. To do so, proceed as follows:

- Fold the knife guard (9) and ejector (84) downward.
- Rotate the clamping lever (11) of the lateral displacement forwards and pull it out sideways.
- Push the knife holder base plate (86) with the pressure plate (83) until it can be removed from the segment arch (87).
- Rotate the blade clamping lever (10) downward and pull it out sideways.
- Remove pressure plate (83).
- Clean all parts of the knife holder.



**If several knife holders are cleaned at the same time, the parts must NOT be mixed up! Failure to adhere to this may result in sectioning problems!**



**For cleaning and removal of paraffin, do not use xylene or cleaning fluids containing alcohol (e.g. glass cleaner).**

- Lay the removed parts on an absorbent cloth into the drying chamber (up to a max. of 65 °C) and let the paraffin contamination run off.
- Dry knife holder and reassemble.



**There is a burn hazard when removing the parts from the drying chamber (65 °C). Wearing safety gloves is recommended!**

- After cleaning the moving parts of the knife holder, apply a thin coat of drive part oil to them (see also [Chap. 8.2.3](#)).
- When installing the pressure plate (83), ensure that the upper edge is parallel to and level with the rear edge of the knife holder base (86) (see also [Fig. 42](#)).

## 8. Cleaning and Maintenance

### Universal cassette clamp

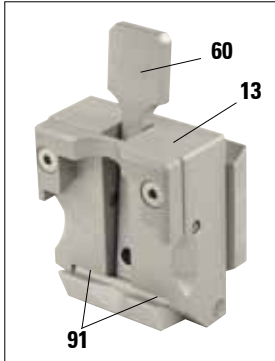

Fig. 75

- Detach cassette clamp (13) for a thorough cleaning, removing all paraffin residues.
- For cleaning, do not use xylene. Use xylene substitutes or paraffin removers such as "Para Gard."
- The cassette clamp (13) can also be placed in an oven heated to a maximum of 65°C, until the liquid wax escapes.
- Remove paraffin residues with a dry cloth.
- After such a cleaning procedure in an oven, always be sure to lubricate the spiral springs (91) of the tension lever (60) and move it back and forth several times.

### 8.2 Maintenance

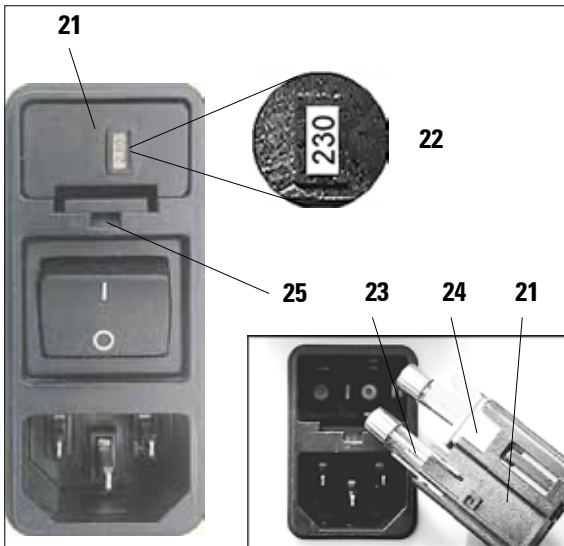

Fig. 76

#### 8.2.1 Replacing fuses



**Switch the unit off and unplug it. Use only the supplied replacement fuses. Both fuses must have the same rating (check the imprint!).**

- Insert a small screwdriver into the cutout (25) and carefully pry out the insert.
- Remove the voltage selector housing (21) together with the fuses (23).
- Remove the fuses. While doing so, leave the voltage selector switch block (24) in the housing.
- Replace defective fuses and reinstall the voltage selector into the instrument.
- Check that the correct voltage value is displayed in the viewing window (22).



### 8.2.2 Maintenance instructions



**Only authorized and qualified service personnel may access the internal components of the instrument for service and repair!**

The instrument is basically maintenance-free.

To ensure trouble-free operation of the instrument over a long period of time, the following is recommended by Leica:

1. Thoroughly clean the instrument on a daily basis.
2. Enter into a service contract at the latest at the end of the warranty period. For more information, please contact your local Leica technical service center.
3. Have the instrument inspected on a regular basis by a qualified service technician authorized by Leica.  
The intervals depend on how heavily the instrument is used.

We recommend the following inspection intervals depending on the general workload of the instrument as defined in the two categories listed in the table:

	Category I	Category II
<b>Number of sections per day:</b>	> 8,000 sections per day	< 8,000 sections per day
<b>Workload (hours per day):</b>	> 5 hours per day	≤ 5 hours per day
<b>Sectioning speed:</b>	Predominantly high sectioning speed	Slow to medium sectioning speed
<b>Specimen material:</b>	Working with soft and hard specimens	Predominantly soft specimen material
<b>Maintenance:</b>	Every 12 months	Every 24 months



#### Note for inspection

- When the instrument reaches approx. 2 million performed strokes, the code **SEr** always appears for approx. 3 seconds in the three-digit display when the **TRIM/SECT** button is pressed (switching between trimming and sectioning mode).  
This is a reminder that the instrument must be inspected by an authorized Leica service technician, regardless of how heavily the instrument has been used.

## 8. Cleaning and Maintenance

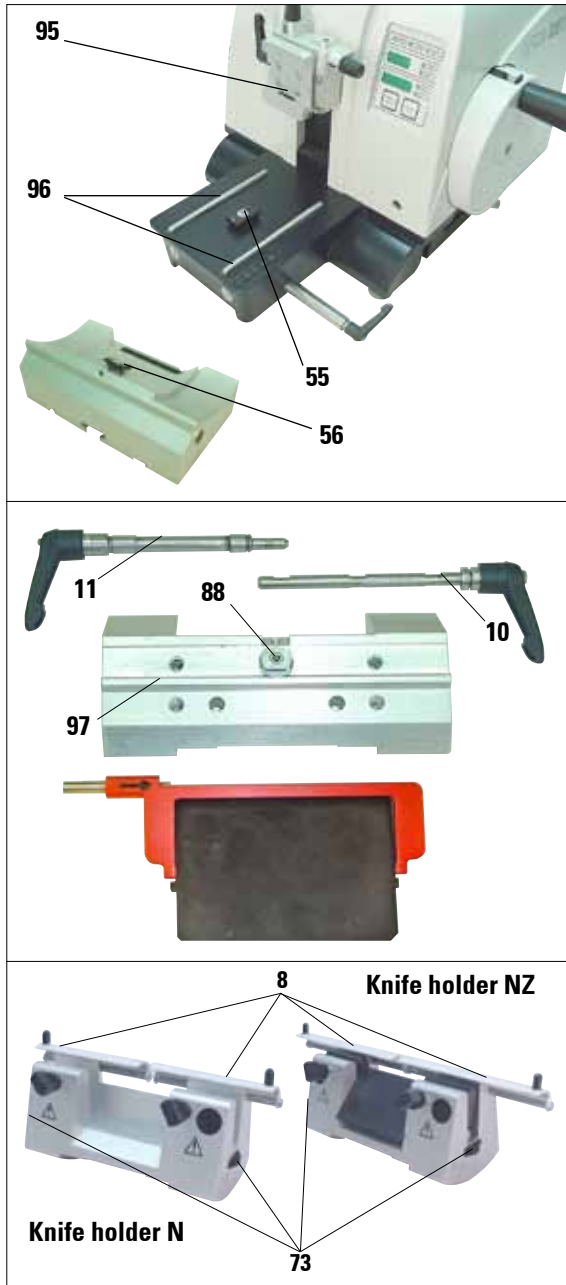

Fig. 81

### 8.2.3 Lubricating the instrument

Once a month, lubricate the following parts with the included drive parts oil No. 405 (1-2 drops are enough).

#### Instrument and specimen holder:

- The clamping key (95) of the quick clamping system.
- The T-piece (55) on the microtome base plate.
- Guide rails (96) for the knife holder base on the microtome base plate.
- The T-piece on the knife holder base (56).

#### Knife holder E:

- Clamping lever (11) for the lateral displacement.
- T-piece (88) and guide (97) of the knife holder for the lateral displacement.
- Clamping lever (10) for the blade.

#### Knife holders N and NZ:

- Sliding surfaces of the finger guard (8).
- Knurled nuts (73) for measuring height adjustment.

### Warranty

Leica Biosystems Nussloch GmbH guarantees that the contractual product delivered has been subjected to a comprehensive quality control procedure based on the Leica in-house testing standards, and that the product is faultless and complies with all technical specifications and/or agreed characteristics warranted.

The scope of the warranty is based on the content of the concluded agreement. The warranty terms of your Leica sales organization or the organization from which you have purchased the contractual product shall apply exclusively.

### Service Information

If you are in need of technical customer support or spare parts, please contact your Leica representative or the Leica dealer where you purchased the instrument.

Please provide the following information:

- Model name and serial number of the instrument.
- Location of the instrument and name of a contact person.
- Reason for the service call.
- Delivery date.

### Decommissioning and Disposal

The instrument or parts of the instrument must be disposed of according to existing applicable, local regulations.

Special attention should be paid to the lithium cell of the electronic circuit board!

# 10. Decontamination Certificate

Dear Customer,

Any product that is to be returned to Leica Biosystems or serviced on site, must be cleaned and decontaminated in the appropriate manner. Since it is not possible to decontaminate for prion diseases, such as CJD, BSE, CWD etc., equipment exposed to specimens containing prion diseases cannot be returned to Leica Biosystems for repair. On-site repair of prion contaminated equipment will only be conducted after the Field Service Engineer has been educated in the risks, instructed in the policies and procedures of the institution, and provided with personal protective equipment. Please fill out this confirmation carefully and enclose a copy with the instrument. Attach the confirmation to the outside of the flight case or hand it directly to the service technician.

Packages will not be opened, nor servicing commenced until the Company or service engineer have received a satisfactory certificate. Should returned goods be considered a hazard by the Company, they will be returned immediately to the customer at his/her expense. **Note:** Microtome knives must be in boxes.

**Mandatory information:** Fields marked with \* are mandatory. Depending on whether the instrument is contaminated, please also complete either section A or section B.

Nameplate information

Model (see nameplate)\*

SN (see nameplate)\*



REF (see nameplate)\*

**Tick Box A if applicable. Otherwise please complete all parts of B, providing further information as requested or appropriate.**

## A

Yes

This equipment has not been in contact with unfixed biological samples.

## B

Yes

No

**1** This equipment has been exposed internally or externally to hazardous materials as indicated below:

Blood, body fluids, pathological samples

**Please provide further detail here:**

Other biohazards

Chemicals/substances hazardous to health

Other hazards

Radioactivity





Yes

No

**2** This equipment has been cleaned and decontaminated:

If yes, give details of the method:

**Please provide further detail here:**

If no\*\*, please indicate why not:

\*\* Such equipment must not be returned without the written agreement of Leica Biosystems.

Yes

No

**3** The equipment has been prepared to ensure safe handling/transportation. Whenever possible, please use the original transportation case/box.

## 10. Decontamination Certificate

**Important - to avoid refusal of shipment:**

Place one copy in the unit prior to packaging, or hand it over to the service engineer. Customer assumes all responsibility for the immediate return shipment of articles sent to Leica without proper decontamination documentation.

If you have any further questions, please call your local Leica organization.

**Leica Internal Use:** If applicable, note corresponding Job and RAN-/RGA-Number:

Job Sheet No.: \_\_\_\_\_ BU Return Authorization Number: \_\_\_\_\_ SU Return Goods Authorization: \_\_\_\_\_

**Signature/Date\***

**Name\***

**Position\***

**eMail**

**Institute\***

**Department\***

**Address\***

**Phone\***

**Fax**

Leica Biosystems Nussloch GmbH  
Heidelberger Str. 17-19  
69226 Nussloch, Germany

Phone: ++49 (0) 6224 143 0  
Fax: ++49 (0) 6224 143 268  
www.LeicaBiosystems.com



**Notes**

---



[www.LeicaBiosystems.com](http://www.LeicaBiosystems.com)



Leica Biosystems Nussloch GmbH  
Heidelberger Straße 17-19  
D- 69226 Nussloch  
Phone: +49 - (0) 6224 - 143 0  
Fax: +49 - (0) 6224 - 143 268  
Web: [www.LeicaBiosystems.com](http://www.LeicaBiosystems.com)